

ILLUSTRATED PARTS LIST

for

SINGER

MACHINE

212 G 140

212 G 141

212 G 145

212 G 146

212 G 340

341

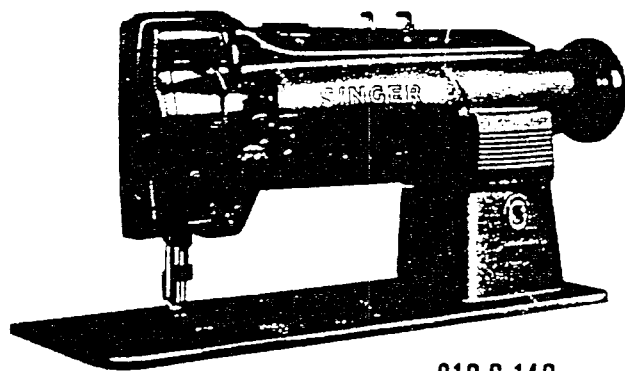

212 G 140

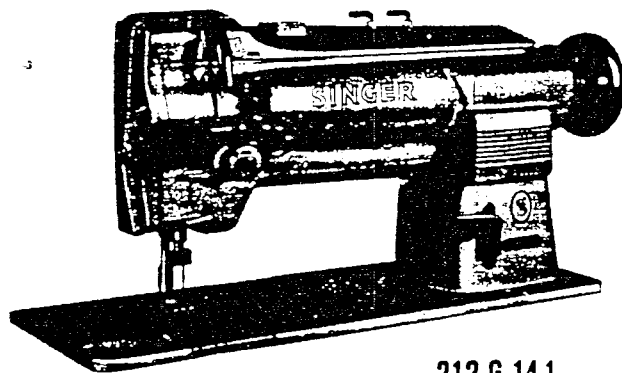

212 G 141

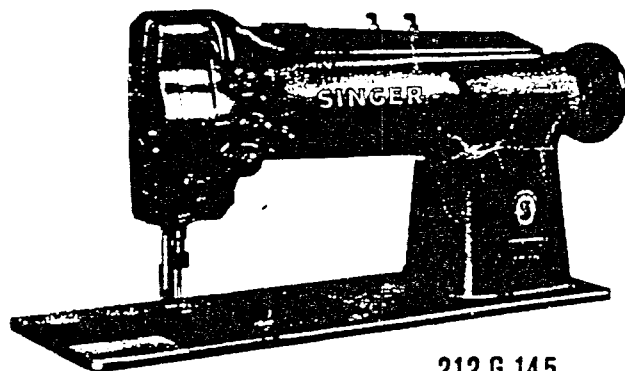

212 G 145

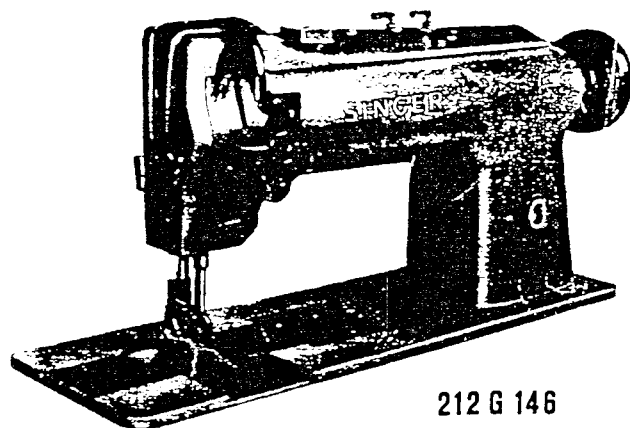

212 G 146

From the library of: Diamond Needle Corp

Form 30-337 G (Rev. 268)

Printed in Western Germany

Ill. Ref. No.	Part No.	For Class 212 G				Name	Components
		140	141	145	146		
1	267224	x	x	x	x	Needle Bar Crank Friction Washer	
2	244747	x	x	x	x	Arm Shaft Bushing	
3	200341-803	x	x	x	x	Arm Shaft Bushing Set Screw	
4	204329	x	x	x	x	Arm Shaft Bushing Oil Pad (Felt) (Lower)	
5	267160	x	x	x	x	Arm Shaft Bushing Oil Pad (Felt) (Upper)	
6	267162	x	x	x	x	Arm Shaft Connection Belt Pulley with	200363, 350492, Two 202253
7	202253	x	x	x	x	Arm Shaft Connection Belt Pulley Spring Flange (2)	
8	350492-803	x	x	x	x	Arm Shaft Connection Belt Pulley Position Screw	
9	200363-833	x	x	x	x	Arm Shaft Connection Belt Pulley Set Screw	
10	267161	x	x	x	x	Arm Shaft Connection Belt (Reinforced Neoprene)	
11	508315	x	-	-	-	Machine Pulley Cpl.	141566, 141567, 272142
12	272142	-	x	-	-	Arm Shaft Ball Bearing (Back) (Double Shielded Bearing)	
13	141566-833	x	-	-	-	Machine Pulley Position Screw	
14	141567-833	x	-	-	-	Machine Pulley Set Screw	
15	267247	x	x	x	x	Arm Shaft with	200333, 200374, 200378, 200388, 267221
16	200374-830	x	x	x	x	Needle Bar Connecting Link Stud Set Screw	
17	200388-803	x	x	x	x	Needle Bar Connecting Stud Set Screw	
18	267221	x	x	x	x	Needle Bar Connecting Link Stud with	267466
19	267466	x	x	x	x	Needle Bar Connecting Link Stud Oil Packing (Wick)	
20	200333-803	x	x	x	x	Needle Bar Crank Position Screw	
21	200378-803	x	x	x	x	Needle Bar Crank Position Screw Check Screw	
22	267239	x	x	x	x	Take-up Lever Hinge Stud with	235706
23	235706	x	x	x	x	Take-up Lever Hinge Stud Oil Packing (Wick)	
24	200383-803	x	x	x	x	Take-up Lever Hinge Stud Set Screw	
25	267300	x	x	x	-	Take-up Lever	
26	202399	x	x	x	x	Take-up Lever Driving Stud with	244071
27	244071	x	x	x	x	Take-up Lever Driving Stud Oil Packing (Wick)	
28	202552	x	x	x	x	Needle Bar Connecting Link	
29	264714	x	x	x	x	Needle Bar Connecting Stud with	200072, 202330
30	200072	x	x	x	x	Needle Bar Connecting Stud Pinch Screw	
31	202330	x	x	x	x	Needle Bar Connecting Stud Oil Packing (Wick)	
32	267267	x	x	x	x	Needle Bar	Two 200141
33	267269	x	x	x	-	Needle Holder with	
34	200141-933	x	x	x	-	Needle Set Screw (2)	
35	001901-12-2	x	-	-	-	Needle (2)	

Parts for Machine No. 212 G 140

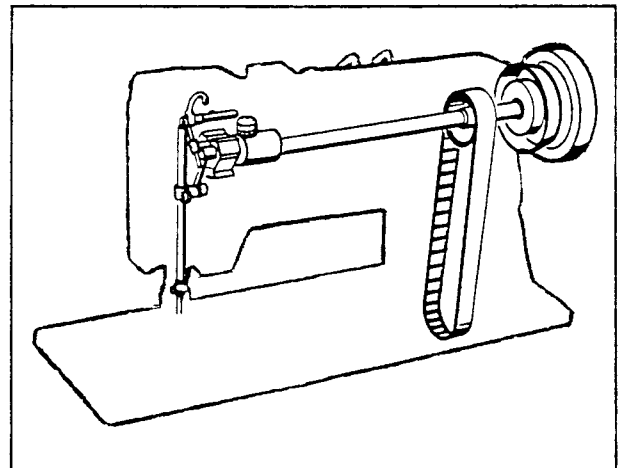
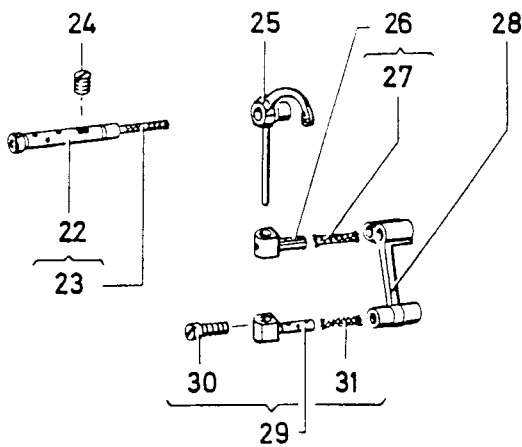
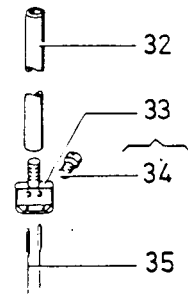
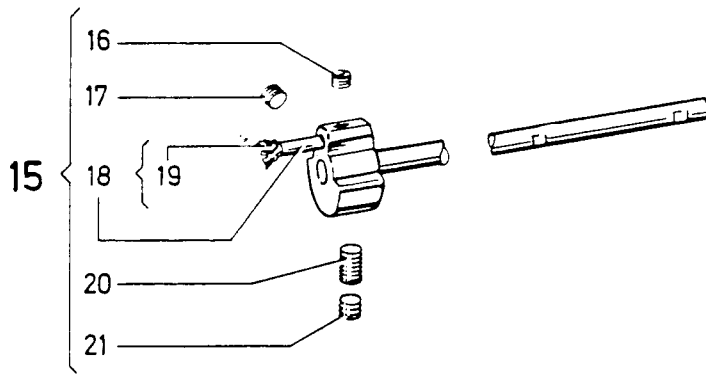
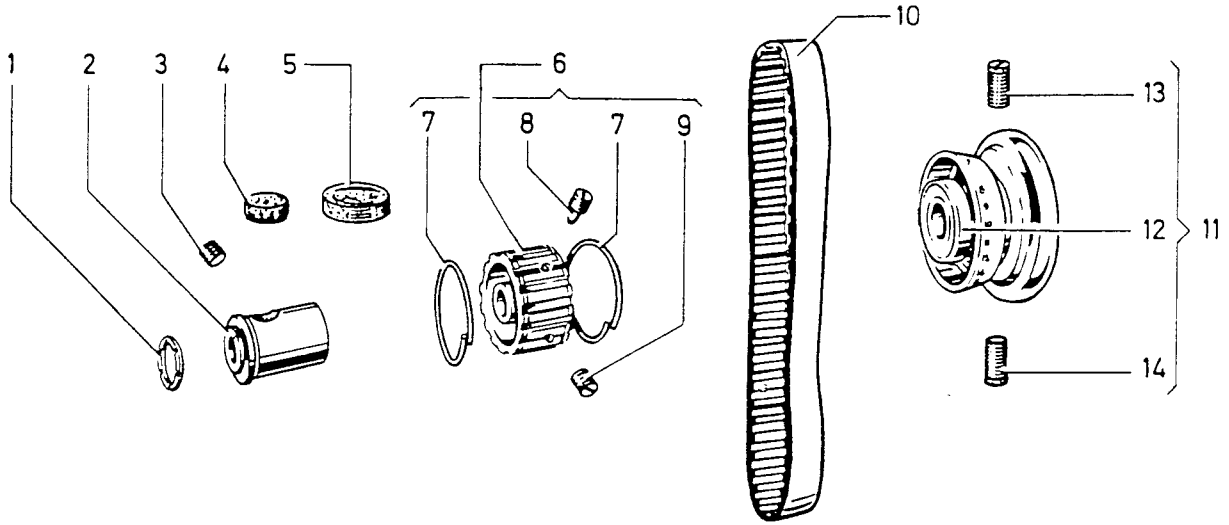

For Class 212 G						Name	Components
Q'ty.	Part No.	140	141	145	146		
1	267286	x	x	-	-	Needle Bar Rock Frame with	Four 200387, Two 267287
2	200387-803	x	x	-	-	Needle Bar Rock Frame Wear Plate Screw (4)	
3	267287	x	x	-	-	Needle Bar Rock Frame Wear Plate (2)	
4	267232	x	x	-	-	Needle Bar Oiling Felt Retainer (Lower)	
5	200176-805	x	x	-	-	Needle Bar Oiling Felt Retainer Screw (Lower) (2)	
6	267231	x	x	-	-	Needle Bar Oiling Felt	
7	267233	x	x	-	-	Needle Bar Oiling Felt Retainer (Upper)	
8	200176-805	x	x	-	-	Needle Bar Oiling Felt Retainer Screw (Upper) (2)	
9	267362	x	x	-	-	Needle Bar Rock Frame Rock Shaft Bushing (Split) (2)	
0	267229	x	x	-	-	Needle Bar Rock Frame Rock Shaft Connection with	200029
1	200029-803	x	x	-	-	Needle Bar Rock Frame Rock Shaft Connection Pinch Screw	
2	267230	x	x	-	-	Needle Bar Rock Frame Rock Shaft Crank Link	
3	350566-803	x	x	-	-	Needle Bar Rock Frame Rock Shaft Crank Link Hinge Screw (2) with	Each one 202277
4	202277	x	x	-	-	Needle Bar Rock Frame Rock Shaft Crank Link Hinge Screw Oil Packing (Wick) (2)	
5	201517-805	x	x	-	-	Needle Bar Rock Frame Rock Shaft Crank Link Hinge Screw Nut (2)	
6	267228	x	x	-	-	Needle Bar Rock Frame Rock Shaft Crank with	200029
7	200029-803	x	x	-	-	Rock Shaft Crank Pinch Screw	
0	267254	x	-	x	x	Bed Oil Tube Clamp	
1	308282	x	-	x	x	Bed Oil Tube Clamp Oiling Felt	
2	267293	x	-	x	x	Feed Driving Eccentric Connection Oil Tube Support	
3	200034-803	x	-	x	x	Bed Oil Tube Clamp Screw	
4	267257	x	-	x	x	Feed Driving Rock Shaft Bushing (Right) Oil Tube	267263
5	267263	x	-	x	x	Feed Driving Rock Shaft Bushing (Right) Oil Tube Wick	
6	267321	x	-	x	x	Bed Oil Supply Tube with	267322
7	267322	x	-	x	x	Bed Oil Supply Tube Oil Wick	
8	267258	x	-	x	x	Hook Saddle Bearing (Left) Oil Tube with	267264
9	267264	x	-	x	x	Hook Saddle Bearing (Left) Oil Tube Wick	
0	267256	x	-	x	x	Feed Driving Rock Shaft Bushing (Left) Oil Tube with	267262
1	267262	x	-	x	x	Feed Driving Rock Shaft Bushing (Left) Oil Tube Wick	
2	267259	x	-	x	x	Hook Saddle Bearing (Right) Oil Tube with	267262
3	267262	x	-	x	x	Feed Driving Rock Shaft Bushing (Left) Oil Tube Wick	
4	267255	x	-	x	x	Feed Driving Eccentric Connection Oil Tube with	267261
5	267261	x	-	x	x	Feed Driving Eccentric Connection Oil Tube Wick	

Parts for Machine No. 212 G 140

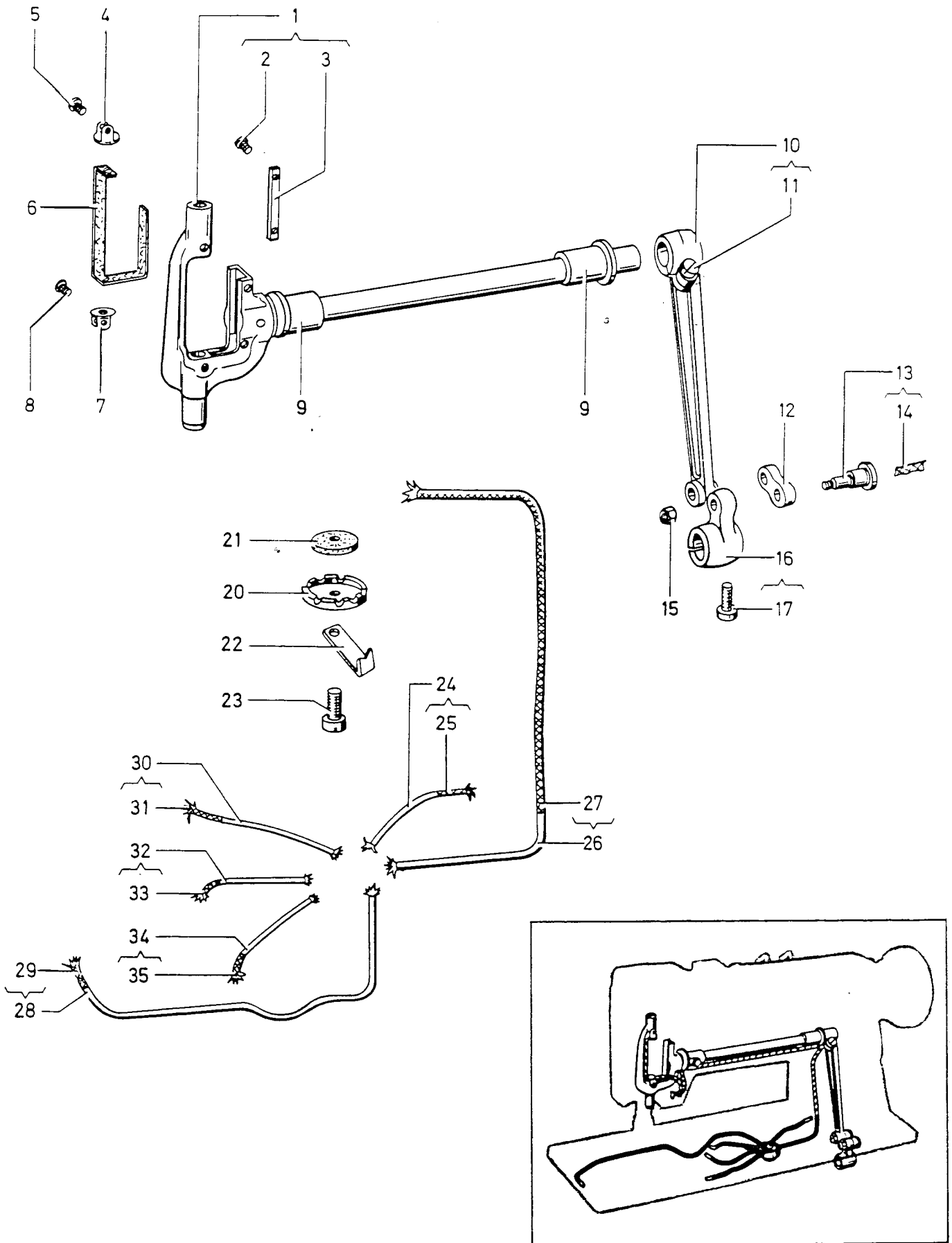

Ill. Ref. No.	For Class 212 G				Name	Components	
	Part No.	140	141	145			146
1	244757	x	x	-	-	Face Plate with	244705, 508283
2	244705	x	x	-	-	Face Plate	
3	508283	x	x	-	-	Face Plate Plug	
4	200047	x	x	x	x	Face Plate Screw (2)	
5	244726	x	x	x	x	Take-up Lever Guard	
6	201341-803	x	x	x	x	Take-up Lever Guard Screw(3)	
7	244751	x	x	x	x	Arm Cover (Top) with	267272
8	267272	x	x	x	x	Oil Lever Indicator	
9	267395	x	x	x	x	Arm Cover (Top) Gasket (Vellumoid)	
10	200047	x	x	x	x	Arm Cover (Top) Screw (6)	
11	271017	x	x	x	x	Thread Guide (Top of Arm) (2)	
12	201525-805	x	x	x	x	Thread Guide (Top of Arm) Lock Nut (2)	
14	267400	x	x	x	x	Dynamic Head-End Lubrication Device Cpl.	267396, 267397, 267398, 267399, Five 237
15	267397	x	x	x	x	Oil Vibrator Pump Bracket	
16	267396	x	x	x	x	Oil Vibrating Pump Block	
17	000237-804	x	x	x	x	Oil Vibrating Pump Block Screw (2)	
18	267398	x	x	x	x	Oil Vibrator Pump Weight	
19	267399	x	x	x	x	Oil Vibrator Pump Weight Spring	
20	000237-804	x	x	x	x	Oil Vibrating Pump Weight Screw	
21	000237-804	x	x	x	x	Oil Vibrating Pump Weight Spring Screw (2)	
22	200133-805	x	x	x	x	Oil Vibrating Pump Bracket Screw (2)	
23	267236	x	x	x	x	Oil Reservoir Oil Wick	
24	267220	x	x	-	-	Oil Guard	
25	200126-805	x	x	x	x	Needle Bar Connecting Link Oil Guard Screw	
26	267152	x	x	-	-	Arm Cover (Side)	
27	350563-805	x	x	-	-	Arm Cover (Side) Screw	
30	223853	x	x	x	x	Bed Slide (Front)	
31	224031	x	x	-	-	Throat Plate	
32	000691-806	x	x	x	x	Throat Plate Screw	
33	200161-804	x	x	x	x	Throat Plate Clamp Screw	
34	223852	x	x	x	x	Bed Slide (Back)	
35	223811	x	x	x	x	Bed Slide (Back) Stop	
36	223812	x	x	x	x	Bed Slide (Back) Stop Spring	
37	224144	x	x	x	x	Attachment Slide Plate with	213479, 236061
38	236061	x	x	x	x	Attachment Slide Plate Friction Slide	
39	213479	x	x	x	x	Attachment Slide Plate Friction Slide Spring	
40	200386-803	x	x	x	x	Attachment Slide Plate (Front) Lock Screw	

Parts for Machine No. 212 G 140

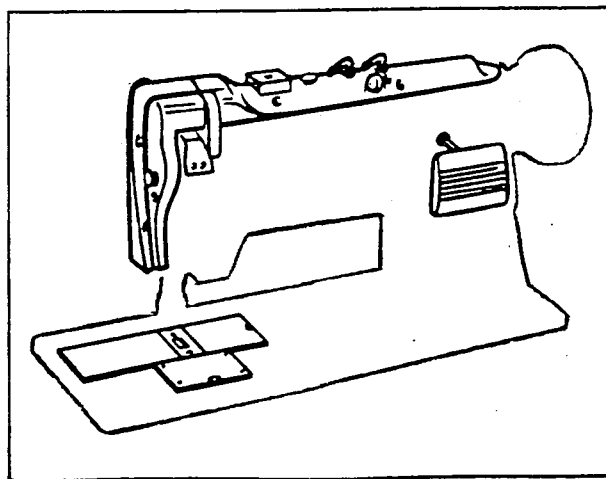
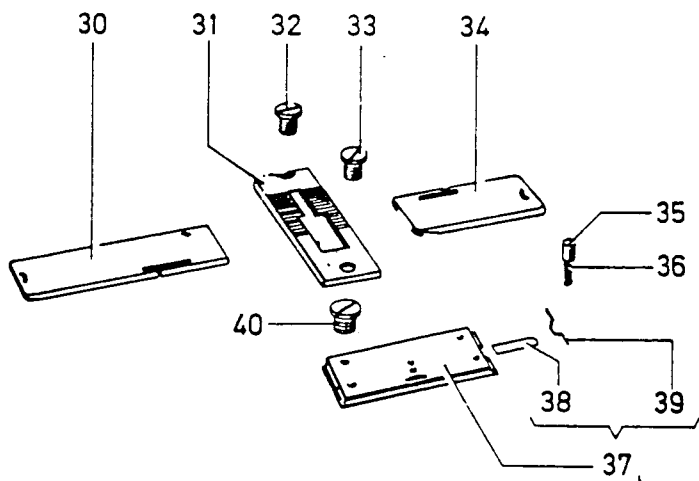
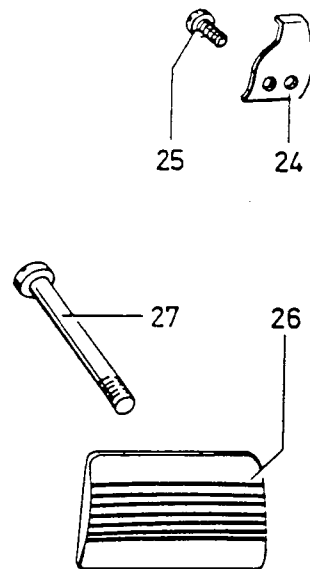
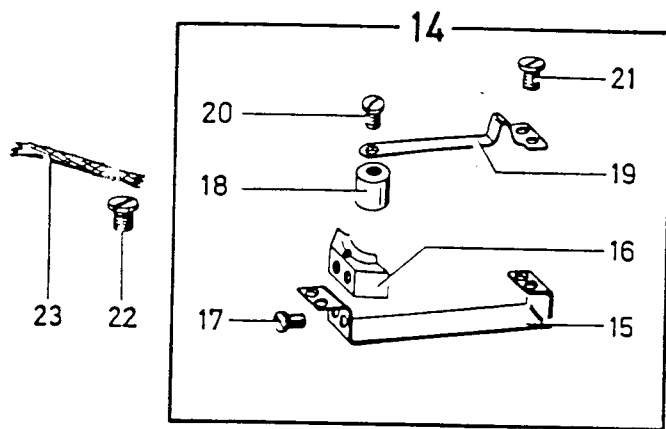
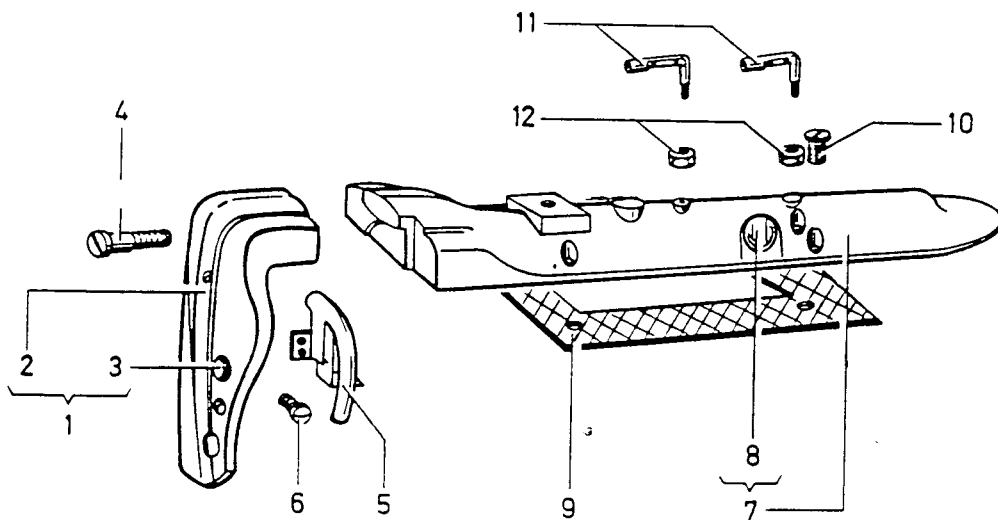

Ill. Ref. No.	Part No.	For Class 212 G				Name	Components
		140	141	145	146		
1	267189	x	x	x	x	Hook Driving Shaft	
2	202254	x	x	x	x	Bed Oil Wick (Front)	
3	267245	x	x	x	x	Feed Regulating Stud	
4	270026	x	x	x	x	Feed Regulating Stud Spring	
5	240245	x	x	x	x	Feed Regulating Stud Retaining Spring	
6	350440	x	x	x	x	Bed Oil Screw	
7	202254	x	x	x	x	Bed Oil Wick (Back)	
8	267195	x	x	x	x	Hook Saddle Bearing (Left)	
9	263093	x	x	x	x	Hook Saddle Bearing (Left)	
						Oil Packing (Wick)	
10	267188	x	x	x	x	Hook Driving Gear (Spir (2) with	Two each 200382 Two each 201220
11	201220-833	x	x	x	x	Feed Lifting Eccentric Set Screw (2)	
12	200382-833	x	x	x	x	Hook Driving Gear Set Screw (2)	
13	267196	x	x	x	x	Hook Saddle Bearing (Right)	
14	223847	x	x	x	x	Hook Saddle Bearing (Right)	
						Oil Packing (Wick)	
15	267033	x	x	x	x	Feed Driving Eccentric Connection Friction Washer	
16	200582-819	x	x	x	x	Feed Driving Eccentric Connection Friction Washer Screw (3)	
17	268064	x	x	x	x	Feed Driving Eccentric	
18	267180	x	x	x	x	Feed Driving Flange with	267623, Two 241763, Two 350467, Two 350477, Two 350548
19	263567	x	x	x	x	Feed Driving Eccentric Friction Plate	
20	350548-803	x	x	x	x	Feed Driving Eccentric Friction Plate Screw (2)	
21	350467-803	x	x	x	x	Feed Driving Flange Set Screw (2)	
22	350477-803	x	x	x	x	Feed Driving Eccentric Friction Plate Screw Set Screw (2)	
23	241763	x	x	x	x	Feed Driving Eccentric Plate Screw Set Screw Packing (Brass) (2)	
24	268065	x	x	x	x	Feed Driving Eccentric Adjusting Disc	
25	268066	x	x	x	x	Feed Driving Eccentric Adjusting Disc Spring	
26	268067	x	x	x	x	Feed Driving Eccentric Adjusting Disc Spring Collar with	Two 200382
27	200382-833	x	x	x	x	Feed Driving Eccentric Adjusting Disc Spring Collar Set Screw (2)	
28	244714	x	x	x	x	Hook Driving Shaft Ball Bearing with	244713, 267190
29	244713	x	x	x	x	Hook Driving Shaft Ball Bearing	
30	267190	x	x	x	x	Hook Driving Shaft Ball Bearing Collar with	200382, 201220
31	201220-833	x	x	x	x	Hook Driving Shaft Ball Bearing Collar Position Screw	
32	200382-833	x	x	x	x	Hook Driving Shaft Ball Bearing Collar Set Screw	
33	267063	x	x	x	x	Hook Driving Shaft Ball Bearing Retaining Washer	
34	200580-819	x	x	x	x	Hook Driving Shaft Ball Bearing Retaining Washer Screw (3)	
35	267192	x	x	-	-	Hook Driving Shaft Connection Belt Pulley with	Two 201254 202253
36	202253	x	x	-	-	Hook Driving Shaft Connection Belt Pulley Spring Flange	
37	201254-803	x	x	-	-	Hook Driving Shaft Connection Belt Pulley Set Screw (2)	

Parts for Machine No. 212 G 140

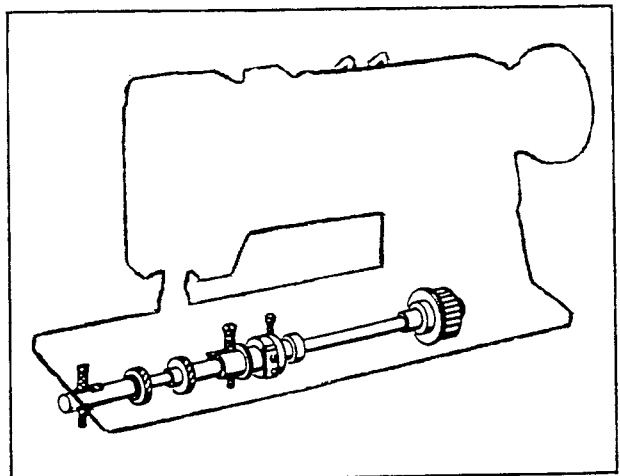
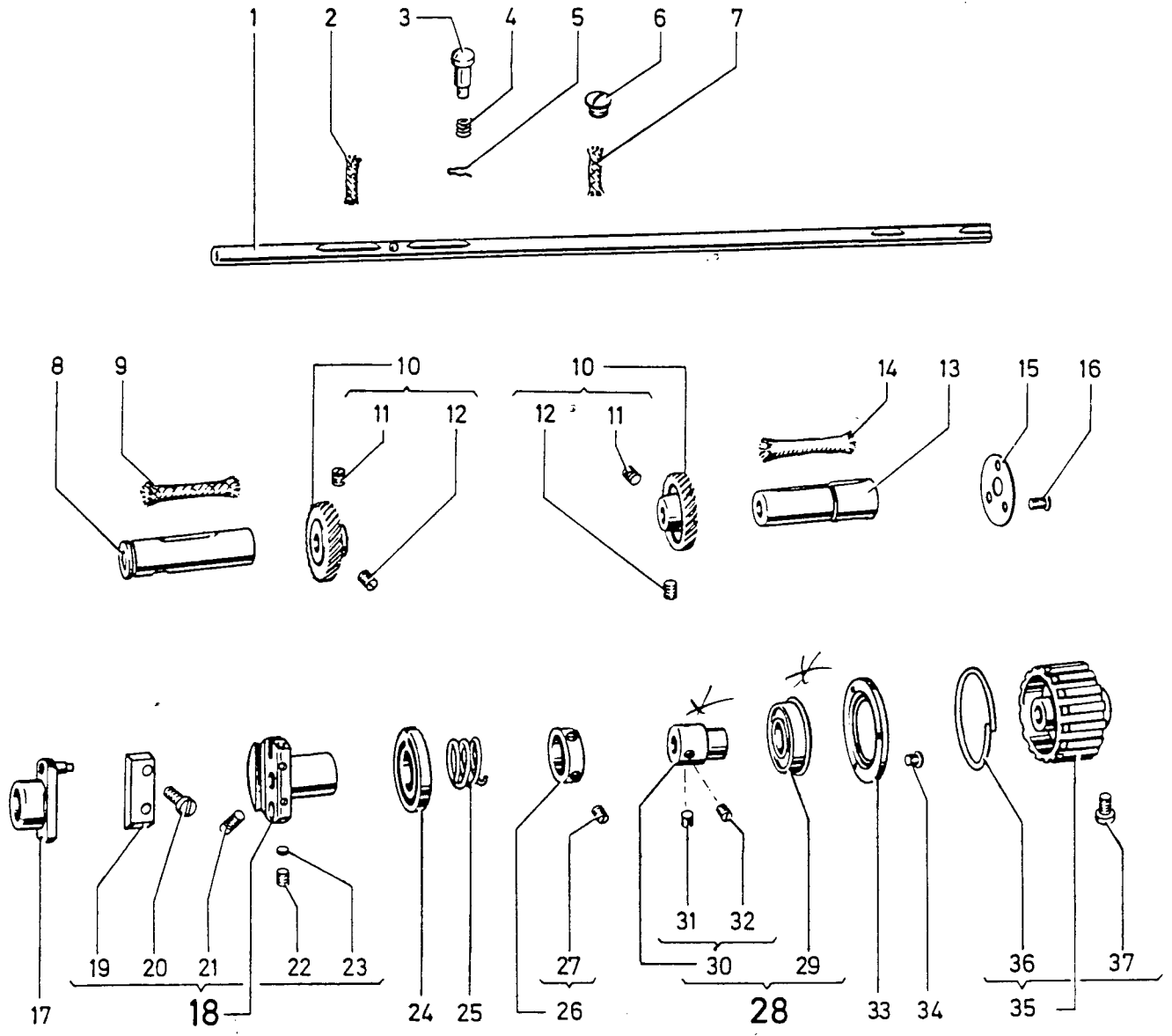

Ill. Ref. No.	Part No.	For Class 212 G				Name	Components
		140	141	145	146		
1	267275	x	x	-	-	Feed Driving Rock Shaft with	201518, 223650, 267274, 350393
2	267274	x	x	-	-	Feed Bar Cpl.	200040, 225837, 248406, 267273
3	267273	x	x	-	-	Feed Lifting Eccentric Fork with	200173, 223655
4	223655	x	x	-	-	Feed Lifting Eccentric Oiling Felt	
5	200173-804	x	x	-	-	Feed Lifting Eccentric Oiling Felt Screw	
6	200040-830	x	x	-	-	Feed Lifting Eccentric Fork Screw	
7	225837	x	x	-	-	Feed Lifting Eccentric Fork Screw Washer	
8	248406	x	x	-	-	Feed Bar Cpl.	200336, 201535
9	200336-805	x	x	-	-	Feed Dog Support Screw	
10	201535-805	x	x	-	-	Feed Dog Support Screw Nut	
11	223650	x	x	-	-	Feed Driving Rock Shaft	
12	350393-803	x	x	-	-	Feed Bar Hinge Screw (Driving)	
13	201518-805	x	x	-	-	Feed Bar Hinge Screw Nut	
14	267182	x	x	x	x	Feed Lifting Eccentric with	201220
15	201220-833	x	x	x	x	Feed Lifting Eccentric Set Screw	
16	223639	x	x	-	-	Feed Dog	
17	200106-805	x	x	x	x	Feed Dog Screw (2)	
18	267032	x	-	x	x	Feed Driving Eccentric Connection with	267031, 268063, 270653
19	267031	x	-	x	x	Feed Driving Eccentric Connection	
20	268063	x	-	x	x	Feed Driving Eccentric Connection Needle Bearing	
21	270653	x	-	x	x	Feed Driving Eccentric Connection Hinge Stud Needle Bearing	
22	267034	x	-	x	x	Feed Driving Eccentric Connection Hinge Stud	
23	267181	x	-	x	x	Feed Driving Rock Shaft Crank with	200029, 200054
24	200054-803	x	-	x	x	Feed Driving Eccentric Connection Hinge Stud Pinch Screw	
25	200029-805	x	-	x	x	Feed Driving Rock Shaft Crank Pinch Screw	
26	244730	x	x	x	x	Feed Driving Rock Shaft Bushing (Left)	
27	202254	x	x	x	x	Bed Oil Wick (Front)	
28	243744	x	x	x	x	Bed Oil Stop Screw Gasket (Front)	
29	350366-819	x	x	x	x	Bed Oil Stop Screw	
30	202625	x	x	x	x	Feed Driving Rock Shaft Stop Collar (2) with	Two each 200383
31	200383-803	x	x	x	x	Feed Driving Rock Shaft Stop Collar Set Screw (4)	
32	244730	x	x	x	x	Feed Driving Rock Shaft Bushing (Right)	
33	202254	x	x	x	x	Bed Oil Wick (Back)	
34	243744	x	x	x	x	Bed Oil Stop Screw Gasket (Back)	
35	350366-819	x	x	x	x	Bed Oil Stop Screw	

Parts for Machine No. 212 G 140

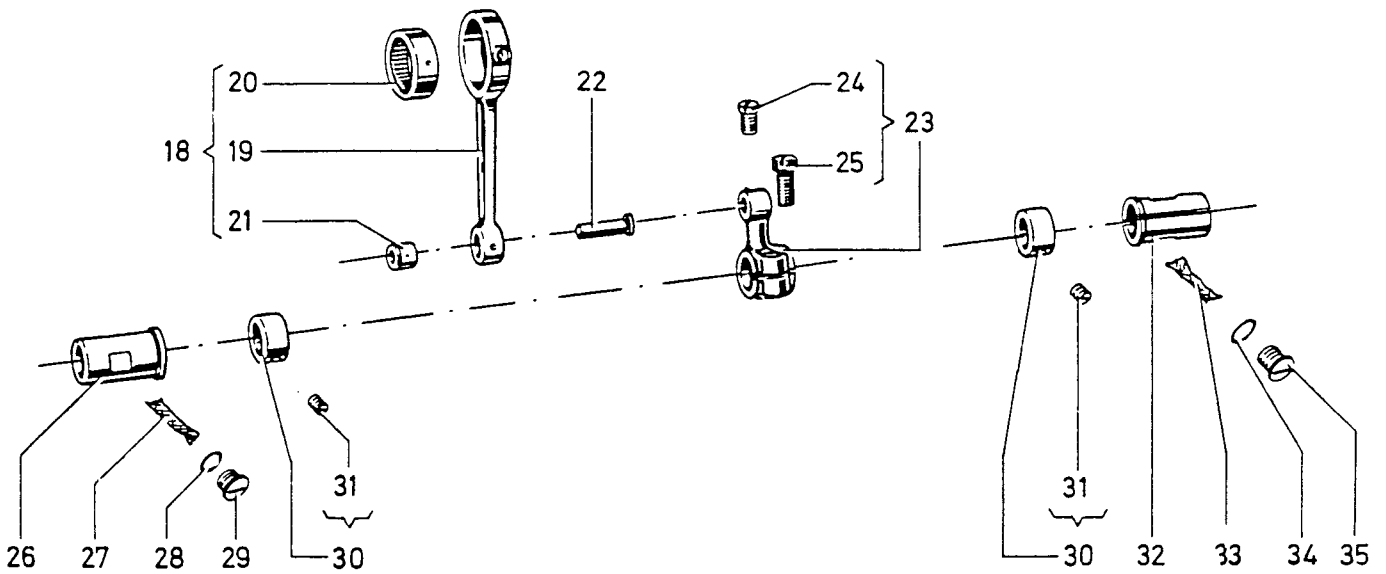
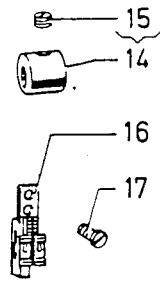
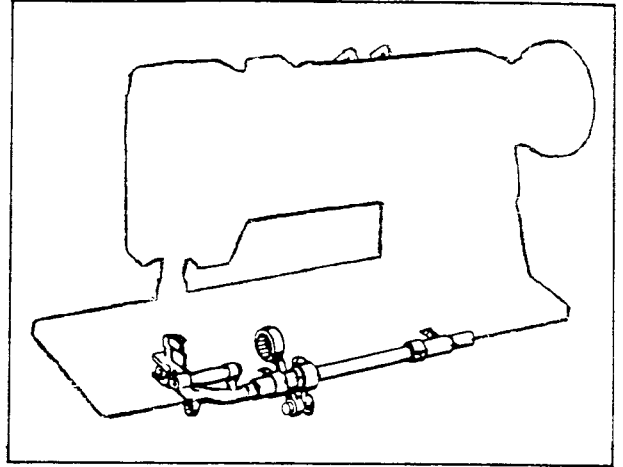
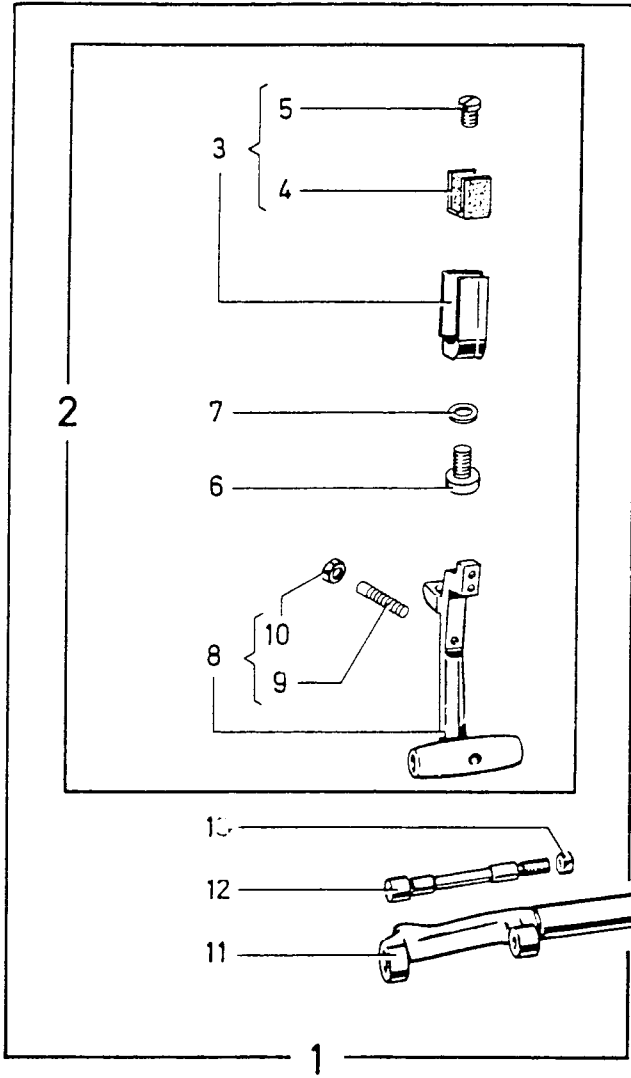

Ill. Ref. No.	Part No.	For Class 212 G				Name	Components
		140	141	145	146		
1	202337	x	x	-	-	Presser Bar Position Guide	
2	200352-833	x	x	-	-	Presser Bar Position Guide Set Screw	
3	202401	x	x	x	x	Take-Up Lever Oiling Felt	
4	200132-805	x	x	x	x	Take-Up Lever Oiling Felt Screw	
5	202671	x	x	x	x	Presser Bar Lifter	
6	200653-803	x	x	x	x	Presser Bar Lifter Hinge Screw	
7	207072	x	x	x	x	Presser Bar Bushing (Upper)	
8	200352-833	x	x	x	x	Presser Bar Bushing Set Screw (Upper)	
9	202338	x	x	-	-	Presser Bar Position Guide Lever with	200086
10	200086-833	x	x	-	-	Presser Bar Position Guide Lever Pinch Screw	
11	206608	x	x	x	x	Presser Bar Lifting Releasing Lever Bracket Spring	
12	267238	x	x	x	x	Presser Bar Lifting Releasing Lever Bracket	
13	210949	x	x	-	-	Presser Bar Spring Bracket with	200086
14	200086-833	x	x	-	-	Presser Bar Spring Bracket Pinch Screw	
15	207072	x	x	x	x	Presser Bar Bushing (Lower)	
16	200352-833	x	x	x	x	Presser Bar Bushing Set Screw (Lower)	
17	208566	x	x	x	-	Presser Bar with	200074
18	200074-806	x	x	x	-	Presser Bar Screw	
19	223799	x	x	-	-	Presser Foot Cpl.	223309, 223798, 230795
20	223309	x	x	-	-	Presser Foot Shank	
21	223798	x	x	-	-	Presser Foot Plate	
22	230795	x	x	-	-	Presser Bar Hinge Pin	
23	240068	x	x	x	x	Knee Lifter Lifting Lever	
24	200738-819	x	x	x	x	Knee Lifter Lifting Lever Spring Stop Screw	
25	267289	x	x	x	x	Knee Lifter Lifting Lever Spring	
26	350464-819	x	x	x	x	Knee Lifter Lifting Lever Hinge Screw	
27	240067	x	x	x	x	Knee Lifter Connection Lever	
28	200262-819	x	x	x	x	Knee Lifter Connection Lever Hinge Screw	
29	350581-803	x	x	x	x	Presser Bar Spring Regulating Screw	
30	227227	x	x	x	x	Knee Lifter Connection Lever Lifting Rod Stop Collar with	200113
31	200113-806	x	x	x	x	Knee Lifter Connection Lever Lifting Rod Stop Collar Set Screw	
32	240564	x	-	x	x	Knee Lifter Connection Lever Lifting Rod	
33	267251	x	x	x	x	Presser Bar Spring (Flat)	
34	200975-806	x	x	x	x	Presser Bar Lifting Releasing Lever Bracket Guide Screw	
35	200948	x	x	x	x	Presser Bar Spring Support Screw	

Parts for Machine No. 212 G 140

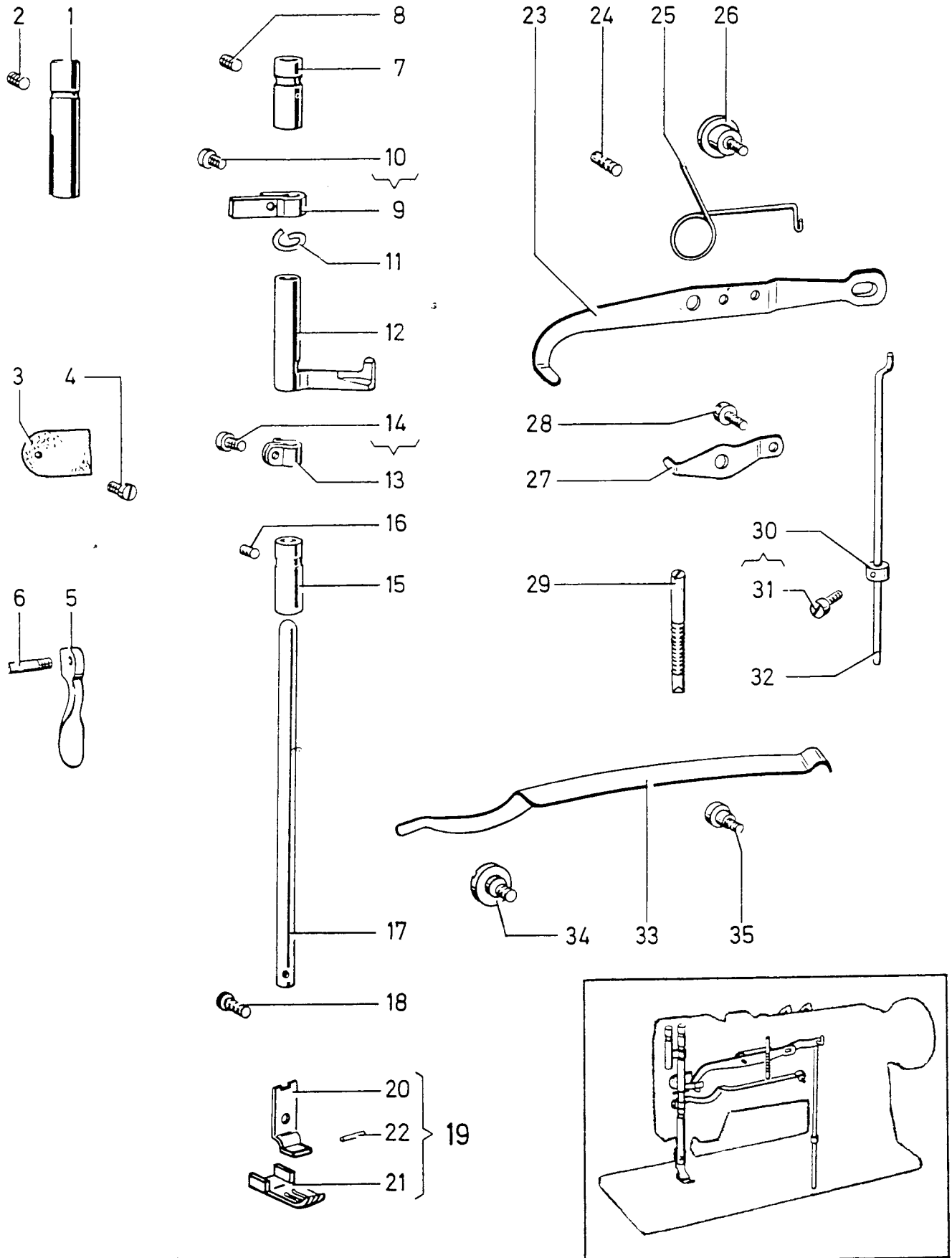

Ill. Ref. No.	For Class 212 G				Name	Components
	Part No.	140	141	145		
1	267369	x	x	-	-	Tension Bracket Cpl. Two 13710, Two 200309 200978, 201199, Three 201572, Two 204271 223702, 223703, Two 223704, 223706, Four 244048 267368
2	223703	x	x	-	-	Tension Release Lever
3	200309-805	x	x	-	-	Tension Release Lever Screw (2)
4	223702	x	x	-	-	Tension Bracket with Two 201224 Two 236060
5	236060	x	x	-	-	Tension Disc Position Pin (2)
6	201224-850	x	x	-	-	Tension Stud (2)
7	244048	x	x	-	-	Tension Disc (4)
8	204271	x	x	-	-	Tension Release Washer (2)
9	013710	x	x	-	-	Tension Spring (2)
10	201572-819	x	x	-	-	Tension Thumb Nut (3)
11	201199-806	x	x	-	-	Thread Controller Stud with 204925
12	267368	x	x	-	-	Thread Controller Spring
13	223706	x	x	-	-	Thread Controller Disc
14	200978-819	x	x	-	-	Thread Controller Disc Screw
15	223704	x	x	-	-	Tension Release Plunger
17	200337-803	x	x	x	x	Thread Controller Stud Set Screw
18	267265	x	x	x	x	Tension Release Lever Rod
19	267316	x	x	x	-	Thread Guide (2)
20	200582-819	x	x	x	-	Thread Guide Screw (3)
21	224040	x	x	-	-	Thread Guide (Lower)
22	241360	x	x	-	-	Thread Controller Spring Stop
23	200132-805	x	x	-	-	Thread Controller Spring Stop Screw
24	267288	x	x	x	x	Thread Retainer
25	200159-806	x	x	x	x	Tension Bracket Screw

Parts for Machine No. 212 G 140

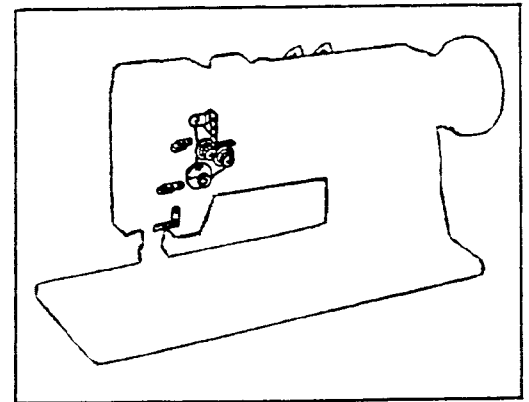
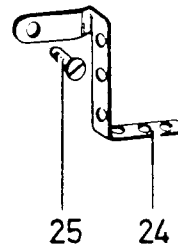
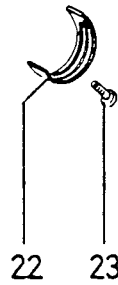
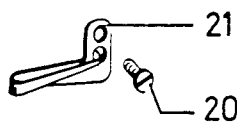
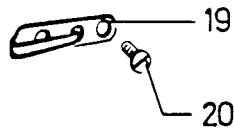
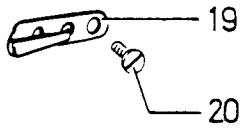
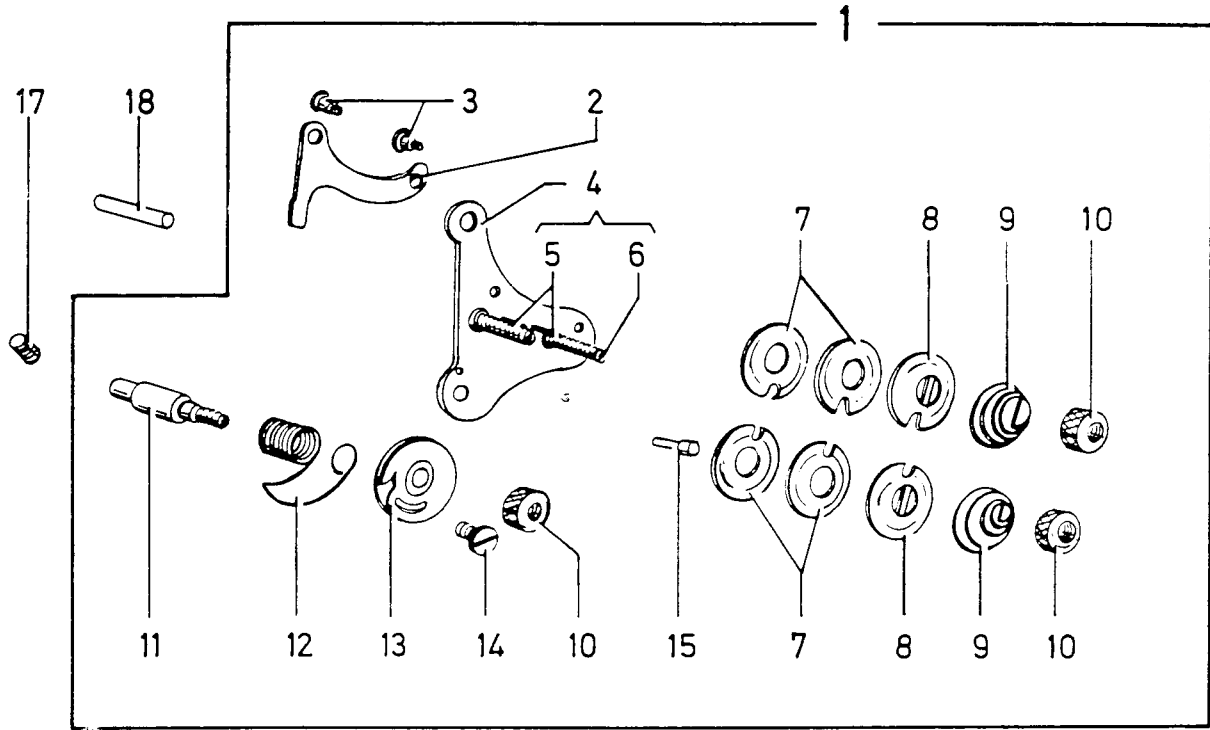

Ill. Ref. No.	Part No.	For Class 212 G				Name	Components
		140	141	145	146		
1	267292	x	x	x	-	Hook Saddle (Right) Cpl.	200110, 267351, 267357, 508279
2	267357	x	x	x	-	Hook and Bobbin Case (Right) Cpl.	236082, 267356
3	267351	x	x	x	-	Bobbin Case Opener	
4	200110-804	x	x	x	-	Bobbin Case Opener Screw	
5	508279	x	x	x	-	Hook Saddle (Right) Cpl.	200374, 200378, 200388, 244084, 244704, 267053, 267166, 267167, 267172, 267194, 267198, 267200, 267212, 267215, 267248, 267365, 267366, 350564, Two each 200089, 200135, 267361, Eight 200061
6	267361	x	x	x	-	Hook Ball Bearing Retainer (2)	
7	200089-819	x	x	x	-	Hook Ball Bearing Screw (2)	
8	267053	x	x	x	-	Hook Ball Bearing	
9	267166	x	x	x	-	Bobbin Case Opener Crank	
10	200135-805	x	x	x	-	Bobbin Case Opener Link Cap Screw	
11	267172	x	x	x	-	Bobbin Case Opener Link (Right)	
12	267167	x	x	x	-	Bobbin Case Opener Crank Hinge Stud (Right)	
13	350564-805	x	x	x	-	Hook Saddle Oil Regulating Screw	
14	244084	x	x	x	-	Feed Driving Rock Shaft Bushing (Right) Pinch Screw Set Screw Packing (Fibre)	
15	200378-803	x	x	x	-	Hook Saddle Oil Regulating Screw Check Screw	
16	200374-830	x	x	x	-	Bobbin Case Opener Crank Hinge Stud (Right) Set Screw	
17	200388-803	x	x	x	-	Bobbin Case Opener Crank Hinge Stud (Right) Set Screw Check Screw	
18	267248	x	x	x	-	Hook Driving Pinion Thrust Bearing	
19	267198	x	x	x	-	Hook Saddle Oil Gauge Sleeve with	267277
20	267277	x	x	x	-	Hook Saddle Oil Strainer	
21	267200	x	x	x	-	Hook Saddle Oil Reservoir (Right)	
22	267212	x	x	x	-	Hook Saddle Oil Reservoir Gasket	
23	200061-833	x	x	x	-	Hook Saddle Oil Reservoir Screw (8)	
24	267194	x	x	x	-	Hook Saddle (Right) with	200185, 267367, 267370, 267371
25	267367	x	x	x	-	Hook Shaft Bushing (Right)	
26	267370	x	x	x	-	Bobbin Case Opener Driving Cam Shaft Bushing (Lower)	
27	200185-804	x	x	x	-	Hook Saddle Oil Stop Screw	
28	267371	x	x	x	-	Bobbin Case Opener Driving Cam Shaft Bushing (Upper)	
29	267366	x	x	x	-	Hook Driving Pinion (Spiral) with	Two 350595
30	350595-850	x	x	x	-	Bobbin Case Opener Driving Cam Shaft Gear Set Screw (2)	
31	267365	x	x	x	-	Bobbin Case Opener Driving Cam Shaft Gear (Spiral) with	Two 350595
32	350595-850	x	x	x	-	Hook Driving Pinion Set Screw (2)	
33	244704	x	x	x	-	Bobbin Case Opener Driving Cam Shaft	
34	200135-805	x	x	x	-	Bobbin Case Opener Link Cap Screw	
35	267215	x	x	x	-	Hook Shaft with	270880, 276061
36	276061	x	x	x	-	Hook Shaft Oil Wick Holder	
37	267880 267880	x	x	x	-	Hook Shaft Oil Wick	
38	267197	x	x	x	x	Hook Saddle Oil Gauge	
39	267140	x	x	x	x	Hook Saddle Pinch Sleeve (Upper)	
40	267139	x	x	x	x	Hook Saddle Pinch Sleeve (Lower)	
41	200001-805	x	x	x	x	Hook Saddle Pinch Sleeve Screw	
42	200006-805	x	x	x	x	Hook Saddle Screw (2)	
43	225585	x	x	x	x	Hook Saddle Screw Washer	

Parts for Machine No. 212 G 140

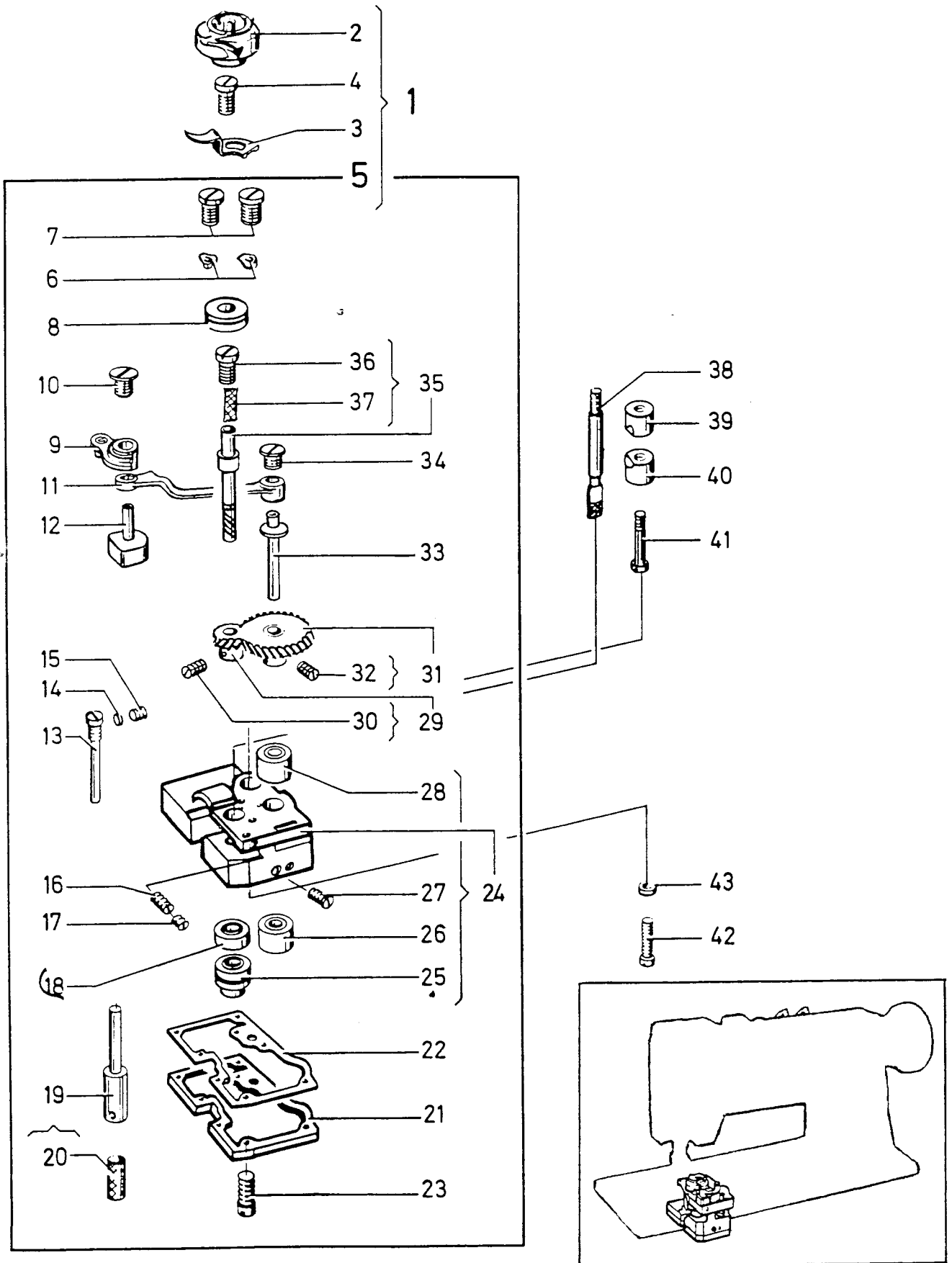

Ill. Ref. No.	Part No.	For Class 212 G				Name	Components
		140	141	145	146		
1	267291	x	x	x	-	Hook Saddle (Left) Cpl.	200110, 267351, 267357, 508280
2	267357	x	x	x	-	Hook and Bobbin Case (Left) Cpl.	236082, 267356
3	267351	x	x	x	-	Bobbin Case Opener	
4	200110-804	x	x	x	-	Bobbin Case Opener Screw	
5	508280	x	x	x	-	Hook Saddle (Left) Cpl.	200378, 244084, 244704, 267017, 267053, 267166, 267171, 267193, 267198, 267199, 267212, 267215, 267248, 267365, 267366, 350564, Two each 200089, 200135, 200143, 267361, Eight 200061
6	267361	x	x	x	-	Hook Ball Bearing Retainer (2)	
7	200089-819	x	x	x	-	Hook Ball Bearing Screw (2)	
8	267053	x	x	x	-	Hook Ball Bearing	270880, 276061
9	267215	x	x	x	-	Hook Shaft with	
10	276061	x	x	x	-	Hook Shaft Oil Wick Holder	
11	270880	x	x	x	-	Hook Shaft Oil Wick	
12	267171	x	x	x	-	Bobbin Case Opener Link (Left)	
13	200135-805	x	x	x	-	Bobbin Case Opener Link Cap Screw	
14	244704	x	x	x	-	Bobbin Case Opener Driving Cam Shaft	
15	267365	x	x	x	-	Bobbin Case Opener Driving Cam Shaft Gear (Spiral) with	Two 350595
16	350595-850	x	x	x	-	Hook Driving Pinion Set Screw (2)	
17	267366	x	x	x	-	Hook Driving Pinion (Spiral) with	Two 350595
18	350595-850	x	x	x	-	Bobbin Case Opener Driving Cam Shaft Gear Set Screw (2)	
19	267193	x	x	x	-	Hook Saddle (Left) with	200185, 267367, 267370, 267371
20	267371	x	x	x	-	Bobbin Case Opener Driving Cam Shaft Bushing (Upper)	
21	200185-804	x	x	x	-	Hook Saddle Oil Stop Screw	
22	267367	x	x	x	-	Hook Shaft Bushing (Left)	
23	267370	x	x	x	-	Bobbin Case Opener Driving Cam Shaft Bushing (Lower)	
24	267199	x	x	x	-	Hook Saddle Oil Reservoir (Left)	
25	267212	x	x	x	-	Hook Saddle Oil Reservoir Gasket	
26	200061-833	x	x	x	-	Hook Saddle Oil Reservoir Screw (8)	
27	267198	x	x	x	-	Hook Saddle Oil Gauge Sleeve with	267277
28	267277	x	x	x	-	Hook Saddle Oil Strainer	
29	267248	x	x	x	-	Hook Driving Pinion Thrust Bearing	
30	350564-805	x	x	x	-	Hook Saddle Oil Regulating Screw	
31	244084	x	x	x	-	Feed Driving Rock Shaft Bushing (Left) Pinch Screw Set Screw Packing (Fibre)	
32	200378-803	x	x	x	-	Hook Saddle Oil Regulating Screw Check Screw	
33	267017	x	x	x	-	Bobbin Case Opener Crank Hinge Bracket (Left)	
34	200143-819	x	x	x	-	Bobbin Case Opener Crank Hinge Bracket (Left) Screw (2)	
35	267166	x	x	x	-	Bobbin Case Opener Crank	
36	200135	x	x	x	-	Bobbin Case Opener Link Cap Screw	
37	267197	x	x	x	x	Hook Saddle Oil Gauge	
38	267140	x	x	x	x	Hook Saddle Pinch Sleeve (Upper)	
39	267139	x	x	x	x	Hook Saddle Pinch Sleeve (Lower)	
40	200001-805	x	x	x	x	Hook Saddle Pinch Sleeve Screw	
41	200006-805	x	x	x	x	Hook Saddle Screw	
42	225585	x	x	x	x	Hook Saddle Screw Washer	

Parts for Machine No. 212 G 140

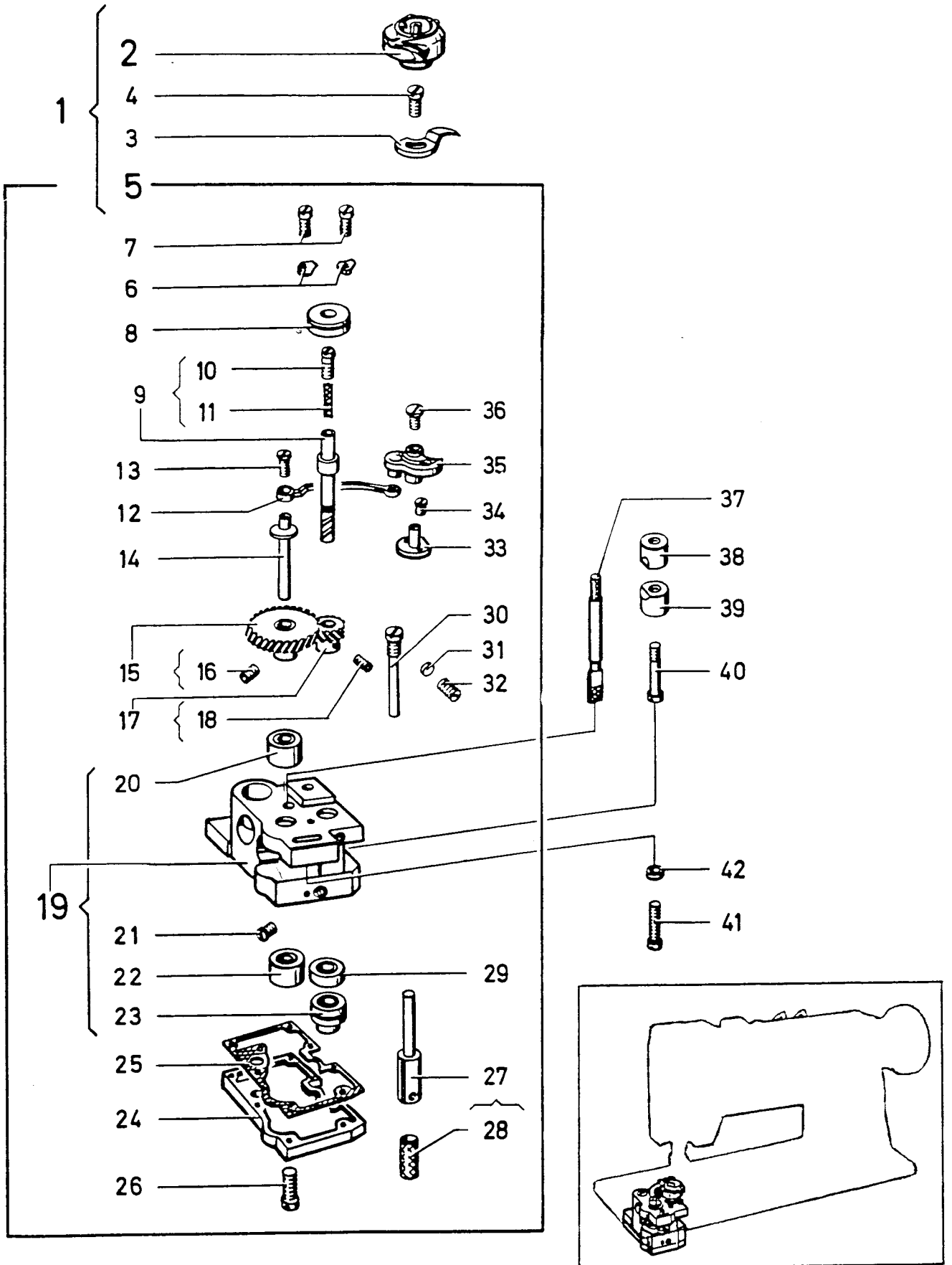

Ill. Ref. No.	Part No.	For Class 212 G				Name	Components
		140	141	145	146		
1	267357	x	x	x	-	Hook and Bobbin Case Cpl. (2) with each	236082, 267356
2	267356	x	x	x	-	Hook with	267355, 267358, 267359, 267360, 350574, Two 200591, Two 201253, Two 201409
3	267358	x	x	x	-	Hook Gib	
4	201253-806	x	x	x	-	Hook Gib Screw (2)	
5	350574-806	x	x	x	-	Hook Height Adjusting Screw	
6	267359	x	x	x	-	Hook Needle Guard	
7	201409-806	x	x	x	-	Hook Needle Guard Screw (2)	
8	267355	x	x	x	-	Hook (Sewing) with	Two 140434
9	140434-833	x	x	x	-	Hook Set Screw (2)	
10	267360	x	x	x	-	Hook Thread Guard	
11	200591-819	x	x	x	-	Thread Guide Screw (2)	
12	236082	x	x	x	-	Bobbin Case Cpl.	200594, 201016, *202056, 203216, 203473, 203474, 203648, *236081, 236083
13	203648	x	x	x	-	Bobbin Case Latch	
*14	202056	x	x	x	-	Bobbin Case Latch Pin	
15	203473	x	x	x	-	Bobbin Case Latch Plunger	
16	203474	x	x	x	-	Bobbin Case Latch Spring	
17	203216	x	x	x	-	Bobbin Case Washer (Cloth)	
*18	236081	x	x	x	-	Bobbin Case	
19	236083	x	x	x	-	Bobbin Case Tension Spring	
20	201016	x	x	x	-	Tension Spring Regulating Screw	
21	200594-805	x	x	x	-	Bobbin Case Tension Spring Screw	
22	244750	x	x	x	-	Bobbin (2)	

Parts marked with an asterisk (*) are furnished only when repairs are made at the factory.

Parts for Machine No. 212 G 140

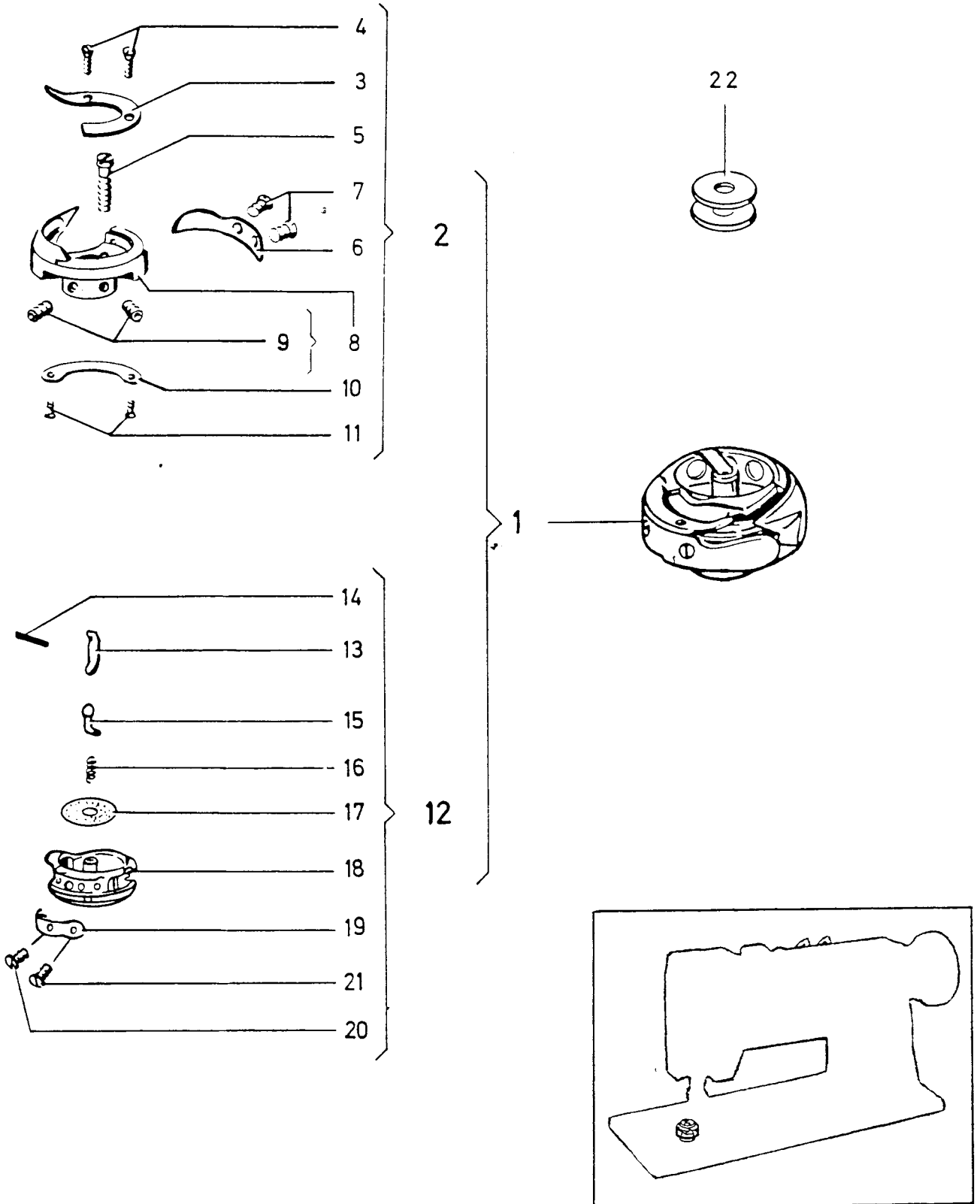

Ill. Ref. No.	Part No.	For Class 212 G				Name	Components
		140	141	145	146		
1	267404	-	x	-	-	Bed Oil Tube Clamp	
2	508282	-	x	-	-	Bed Oil Tube Clamp Oiling Felt	
3	267293	-	x	-	-	Feed Driving Eccentric Connection Oil Tube Support	
4	200025-803	-	x	-	-	Bed Oil Tube Clamp Screw	267422
5	267421	-	x	-	-	Hook Saddle Bearing (Left) Oil Tube with	
6	267422	-	x	-	-	Hook Saddle Bearing (Left) Oil Tube Wick	
7	267408	-	x	-	-	Feed Driving Eccentric Connection Oil Tube with	267409
8	267409	-	x	-	-	Feed Driving Eccentric Connection Oil Tube Wick	
9	267423	-	x	-	-	Hook Saddle Bearing (Right) Oil Tube with	267424
10	267424	-	x	-	-	Hook Saddle Bearing (Right) Oil Tube Wick	
11	267410	-	x	-	-	Feed Driving Rock Shaft Bushing (Left) Oil Tube with	267411
12	267411	-	x	-	-	Feed Driving Rock Shaft Bushing (Left) Oil Tube Wick	
13	267412	-	x	-	-	Feed Driving Rock Shaft Bushing (Right) Oil Tube with	267413
14	267413	-	x	-	-	Feed Driving Rock Shaft Bushing (Right) Oil Tube Wick	
15	267403	-	x	-	-	Bed Oil Supply Tube with	267260
16	267260	-	x	-	-	Bed Oil Supply Tube Oil Wick	
19	240550	-	x	-	-	Knee Lifter Connection Lever Lifting Rod	
20	508314	-	x	-	-	Machine Pulley Cpl.	141566, 141567, 272142
21	141566-833	-	x	-	-	Machine Pulley Position Screw	
22	272142	-	x	-	-	Arm Shaft Ball Bearing (Back) (Double Shielded Bearing)	
23	141567-833	-	x	-	-	Machine Pulley Set Screw	
24	001901-14-2	-	x	-	-	Needle (2)	

Parts for Machine No. 212 G 141

For Parts not illustrated and/or indicated by reference numbers, refer to Machine 212 G 140

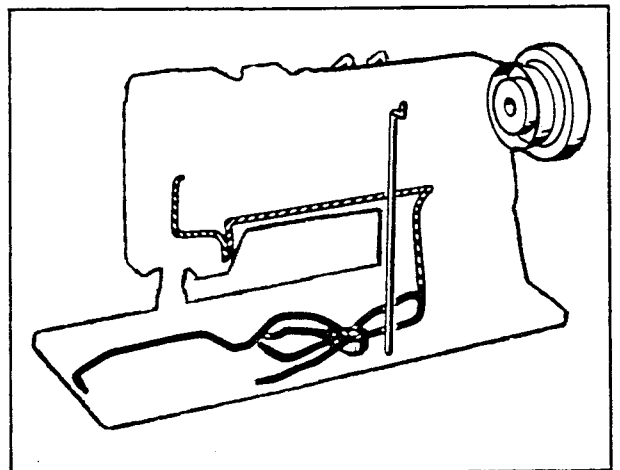
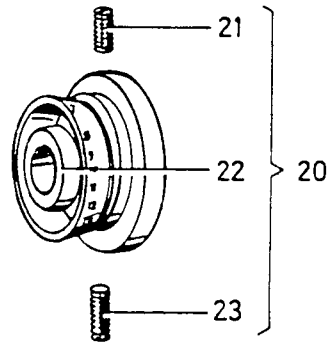
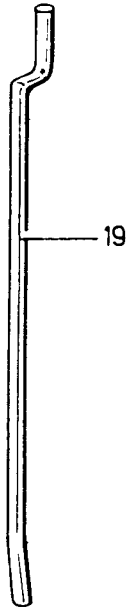
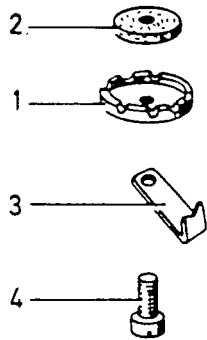
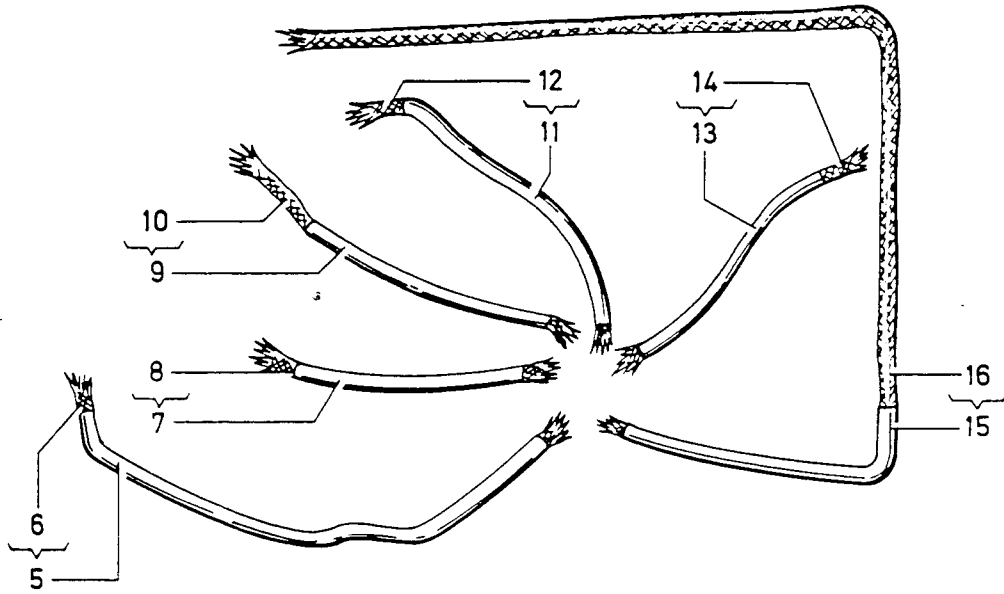

Ill. Ref. No.	Part No.	For Class 212 G				Name	Components
		140	141	145	146		
1	276160	-	x	-	-	Feed Reversing Lever Handle	
2	201529-819	-	x	-	-	Feed Reversing Lever Handle Screw Nut	
3	267414	-	x	-	-	Feed Reversing Lever <i>412107</i>	
4	240574	-	x	-	-	Feed Reversing Lever Guide Roller Position Plate	
5	201829	-	x	-	-	Feed Reversing Lever Guide Roller	
6	200274-803	-	x	-	-	Feed Reversing Lever Guide Roller Screw Stud	
7	200575-819	-	x	-	-	Feed Reversing Lever Handle Screw	
8	000691-806	-	x	-	-	Feed Reversing Lever Guide Roller Position Plate Screw (2)	
9	200247-803	-	x	-	-	Feed Reversing Lever Hinge Screw	267417, 200047
10	508354	-	x	-	-	Feed Reversing Shaft with	
11	267417	-	x	-	-	Feed Reversing Shaft	
12	200047-805	-	x	-	-	Feed Reversing Shaft Driving Stud Pinch Screw	
13	267419	-	x	-	-	Feed Reversing Shaft Driving Stud	
14	267416	-	x	-	-	Feed Reversing Lever Spring Collar with	Two 200382
15	200382-833	-	x	-	-	Feed Reversing Lever Spring Collar Set Screw (2)	
16	267415	-	x	-	-	Feed Reversing Lever Spring	
17	267418	-	x	-	-	Feed Reversing Shaft Bracket with	200364
18	200364-803	-	x	-	-	Feed Reversing Mechanism Support Link Stud Set Screw	
19	200029-805	-	x	-	-	Feed Reversing Shaft Bracket Screw (Left)	
20	253168	-	x	-	-	Bed Oil Cup (2)	
21	200019-805	-	x	-	-	Feed Reversing Shaft Bracket Screw (Right)	
22	232244	-	x	-	-	Feed Reversing Shaft Bracket Position Pin (2)	
23	508341	-	x	-	-	Feed Reversing Shaft Crank Hinge Stud with	276046, 508342
24	508342	-	x	-	-	Feed Reversing Shaft Crank Hinge Stud	
25	276046	-	x	-	-	Feed Reversing Shaft Crank Hinge Stud Oil Packing (Wick)	
26	270830-001	-	x	-	-	Feed Reversing Shaft Crank with	200040, 200386
27	200386-803	-	x	-	-	Feed Reversing Shaft Crank Hinge Stud Set Screw	
28	200040-830	-	x	-	-	Feed Reversing Shaft Crank Pinch Screw	
29	276163	-	x	-	-	Feed Reversing Shaft Crank Link with	200394
30	200394-803	-	x	-	-	Feed Driving Eccentric Connection Link Hinge Pin Set Screw	
31	276173	-	x	-	-	Feed Reversing Mechanism Support Link with	200386
32	200386-803	-	x	-	-	Feed Reversing Shaft Crank Hinge Stud Set Screw	
33	276174	-	x	-	-	Feed Reversing Mechanism Support Link Stud	
34	350507-803	-	x	-	-	Feed Driving Rock Shaft Crank Hinge Screw	
35	267406	-	x	-	-	Feed Driving Eccentric Connection Link	
36	240589	-	x	-	-	Feed Driving Rock Shaft Crank with	200029
37	200029-805	-	x	-	-	Feed Driving Rock Shaft Crank Pinch Screw	
38	201531-805	-	x	-	-	Feed Driving Rock Shaft Crank Hinge Screw Nut	
39	276171	-	x	-	-	Feed Driving Eccentric Connection Link Hinge Pin with	244071
40	244071	-	x	-	-	Feed Driving Eccentric Connection Link Hinge Pin Oil Packing (Wick)	
41	267405	-	x	-	-	Feed Driving Eccentric Connection with	240227, 267407
42	240227	-	x	-	-	Feed Driving Eccentric Connection Oiling Felt Retaining Wire	
43	267407	-	x	-	-	Feed Driving Eccentric Connection Oiling Felt	

Parts for Machine No. 212 G 141

For Parts not illustrated and/or indicated by reference numbers, refer to Machine 212 G 140

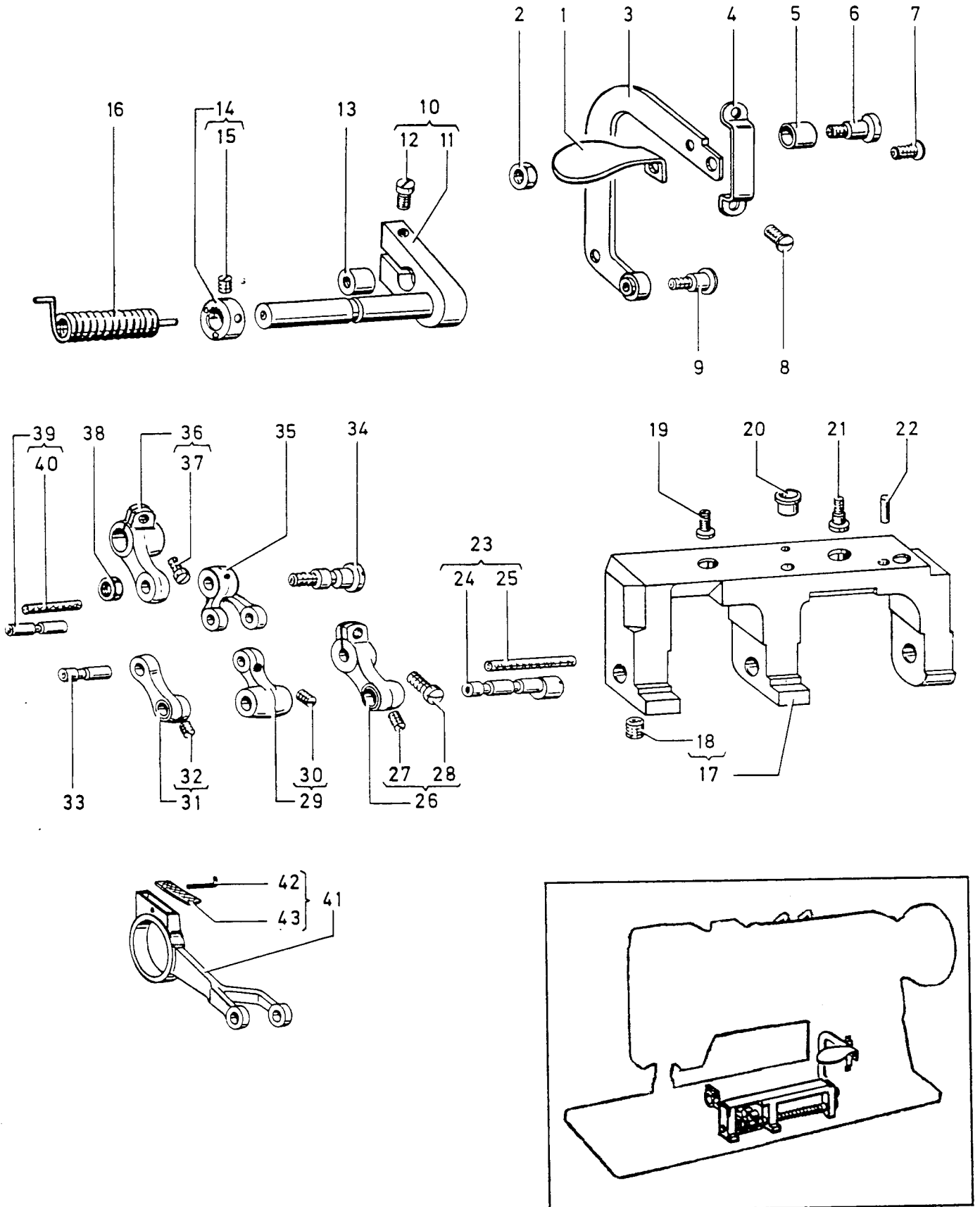

From the library of: Diamond Needle Corp

11. ef. p.		For Class 212 G				Name	Components
o.	Part No.	140	141	145	146		
1	267318	-	-	x	x	Feed Driving Rock Shaft with	201518, 248502,
2	267274	-	-	x	x	Feed Bar Cpl.	267274, 350393,
3	267273	-	-	x	x	Feed Lifting Eccentric Fork with	200040, 225837,
4	223655	-	-	x	x	Feed Lifting Eccentric Oiling Felt	248406, 267273
5	200173-804	-	-	x	x	Feed Lifting Eccentric Oiling Felt Screw	200173, 223655
6	200040-830	-	-	x	x	Feed Lifting Eccentric Fork Screw	
7	225837	-	-	x	x	Feed Lifting Eccentric Fork Screw Washer	
8	248406	-	-	x	x	Feed Bar Cpl.	200336, 201535
9	200336-805	-	-	x	x	Feed Dog Support Screw	
10	201535-805	-	-	x	x	Feed Dog Support Screw Nut	
11	248502	-	-	x	x	Feed Driving Rock Shaft	
12	350393-803	-	-	x	x	Feed Bar Hinge Screw (Driving)	→ Use 4/1 2089
13	201518-805	-	-	x	x	Feed Bar Hinge Screw Nut	
15	267341	-	-	x	-	Face Plate	
16	508310	-	-	x	x	Machine Pulley with	141566, 141567,
17	141566-833	-	-	x	x	Machine Pulley Position Screw	272142
18	272142	-	-	x	x	Arm Shaft Ball Bearing (Back) (Double Shielded Bearing)	
19	141567-833	-	-	x	x	Machine Pulley Set Screw	
20	267308	-	-	x	x	Needle Bar Connecting Link Oil Guard	
21	267304	-	-	x	x	Hook Driving Shaft Connection Belt Pulley with	202253, *
22	202253	-	-	x	x	Hook Driving Shaft Connection Belt Pulley Spring Flange	Two 201254
23	201254-803	-	-	x	x	Hook Driving Shaft Connection Belt Pulley Set Screw (2)	
24	236403	-	-	x	-	Feed Dog	
25	236405	-	-	x	-	Throat Plate	
26	270149	-	-	x	-	Thread Guide	

Parts for Machine No. 212 G 145

For Parts not illustrated and/or indicated by reference numbers, refer to Machine to 212 G 140

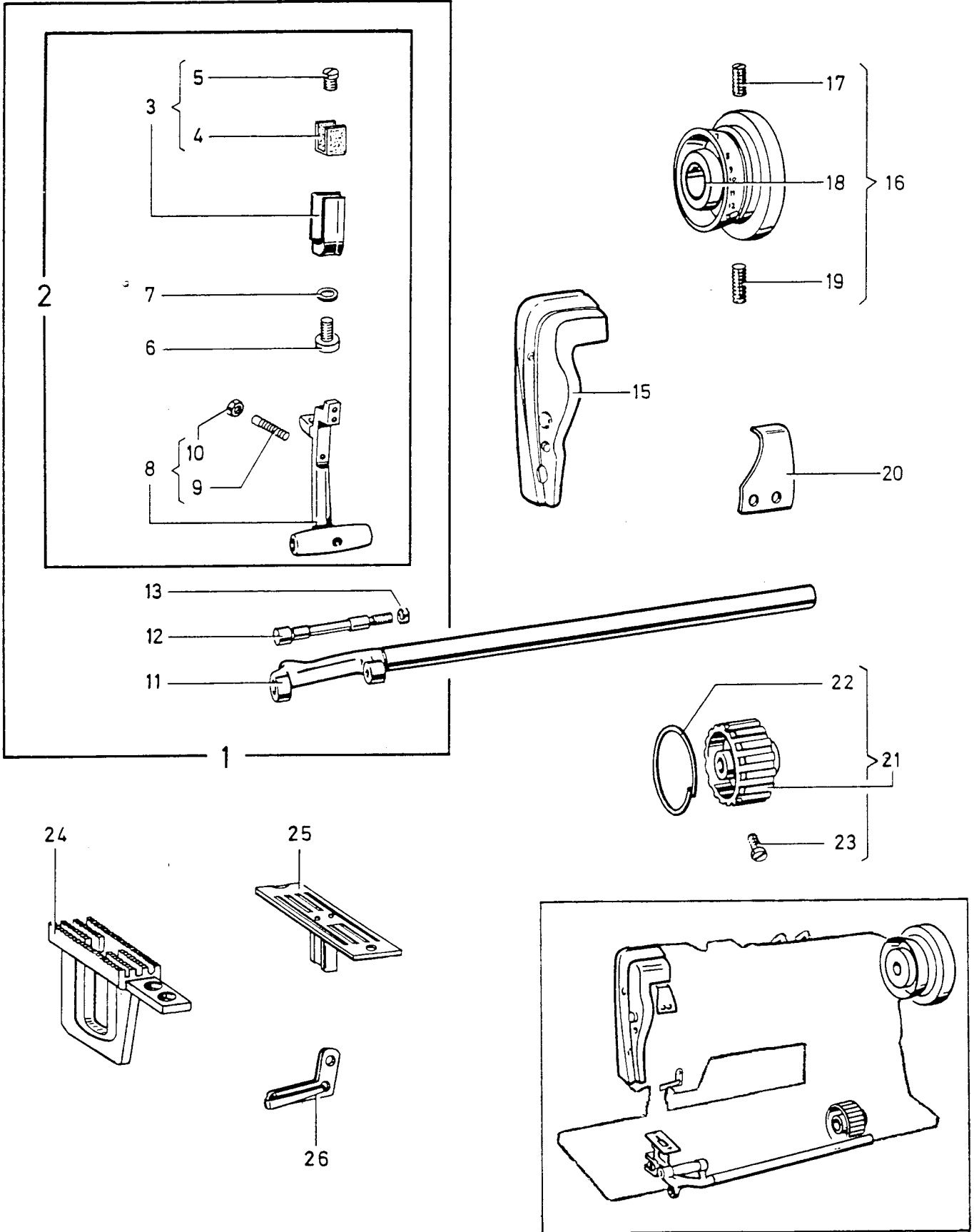

Ill. Ref. No.	For Class 212 G				Name	Components	
	Part No.	140	141	145			146
1	267314	-	-	x	-	Tension Cpl.	201199, 223702, 223703, 223706, 237174, 267315, 350588, Two 013710, Two 200309, Two 204271, Two 223704, Three 201572, Four 244048
2	223703	-	-	x	-	Tension Release Lever	
3	200309-805	-	-	x	-	Tension Release Lever Screw (2)	
4	223702	-	-	x	-	Tension Bracket with	Two 201224, Two 236060
5	236060	-	-	x	-	Tension Disc Position Pin (2)	
6	201224-850	-	-	x	-	Tension Stud (2)	
7	244048	-	-	x	-	Tension Disc (4)	
8	204271	-	-	x	-	Tension Release Washer (2)	
9	013710	-	-	x	-	Tension Spring (2)	
10	201572-819	-	-	x	-	Tension Thumb Nut (3)	
11	201199-806	-	-	x	-	Thread Controller Stud	
12	237174	-	-	x	-	Thread Controller Spring	
13	267315	-	-	x	-	Thread Controller Spring Stop	
14	223706	-	-	x	-	Thread Controller Disc	
15	350588-819	-	-	x	-	Thread Controller Disc Screw	
16	223704	-	-	x	-	Tension Release Plunger (2)	

Parts for Machine No. 212 G145

For Parts not illustrated and/or indicated by
reference numbers, refer to Machine 212 G140

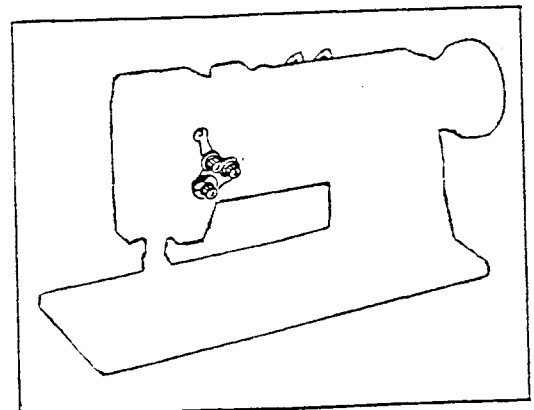
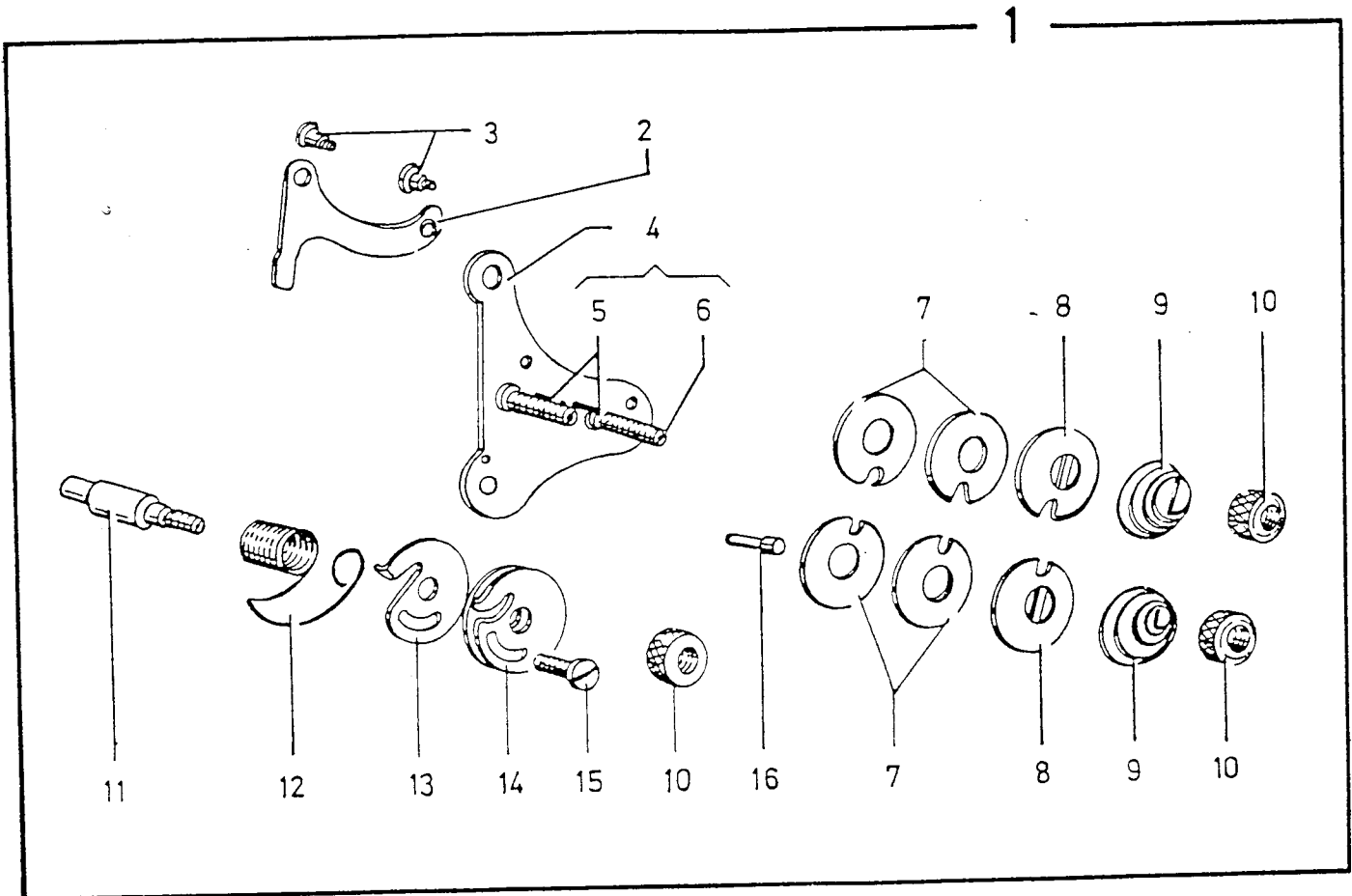

Ill. Ref. No.	Part No.	For Class 212 G				Name	Components
		140	141	145	146		
1	235901	-	-	x	x	Presser Bar Position Guide with	200054
2	200054-805	-	-	x	x	Presser Bar Position Guide Pinch Screw	
3	267313	-	-	x	x	Presser Bar Spring Bracket with	200086
4	200086-833	-	-	x	x	Presser Bar Spring Bracket Pinch Screw	
5	267317	-	-	x	x	Needle Bar Bushing (Upper)	
6	200352-833	-	-	x	x	Needle Bar Bushing Set Screw (Upper)	
7	267310	-	-	x	x	Needle Bar Oiling Felt (Upper)	
8	267312	-	-	x	x	Needle Bar Oiling Felt (Upper) Retainer	
9	267310	-	-	x	-	Oiling Felt (Lower) Retainer	
10	200904-819	-	-	x	-	Needle Bar Oiling Felt (Lower) Retainer Screw	
11	267309	-	-	x	x	Needle Bar Oiling Felt (Lower)	
12	235871	-	-	x	x	Needle Bar Bushing (Lower)	
13	200352-833	-	-	x	x	Needle Bar Bushing Set Screw (Lower)	
14	267307	-	-	x	x	Needle Bar Connection Link Guide Block	
15	200051-805	-	-	x	x	Needle Bar Connecting Link Guide Block Screw (2)	
16	229102	-	-	x	-	Presser Foot	

Parts for Machine No. 212 G 145

For Parts not illustrated and/or indicated by reference numbers, refer to Machine 212 G 140

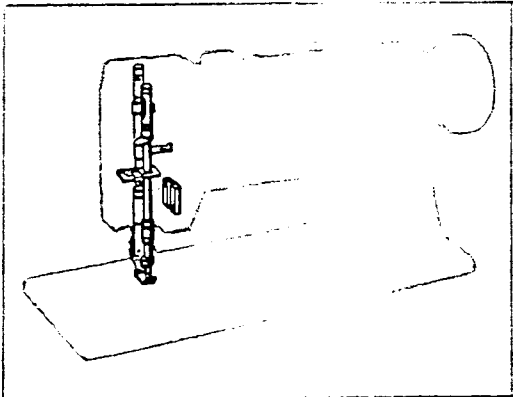
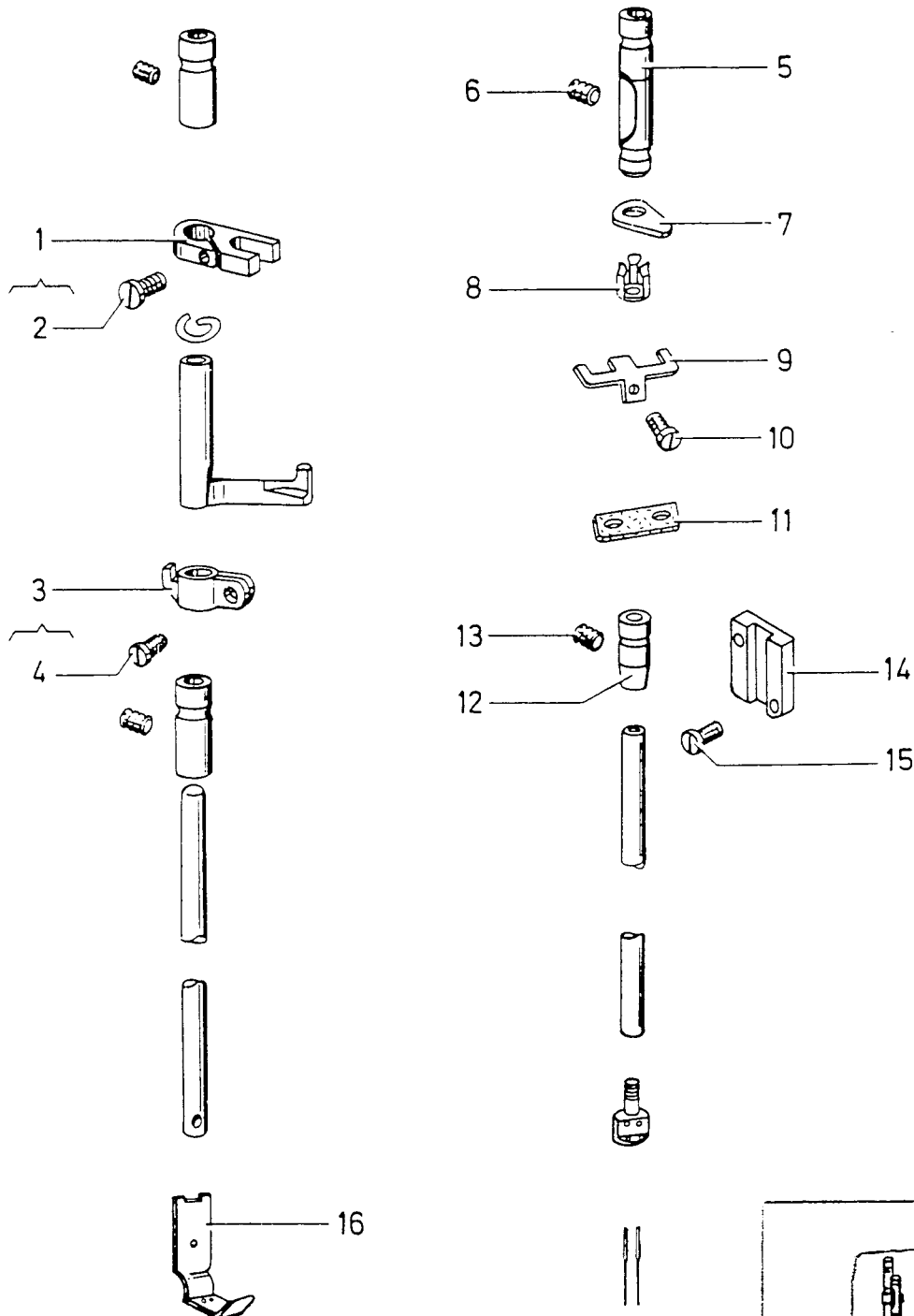

Ill. Ref. No.	Part No.	For Class 212 G				Name	Components
		140	141	145	146		
1	267330	-	-	-	x	Needle Bar Oiling Felt (Lower) Retainer	
2	200904-819	-	-	-	x	Needle Bar Oiling Felt (Lower) Retainer Screw	
3	267331	-	-	-	x	Needle Holder	
4	200141-806	-	-	-	x	Needle Set Screw (2)	
5	001740-13-1	-	-	-	x	Needle (2)	
6	265791	-	-	-	x	Take-Up Lever	
7	267246	-	-	-	x	Thread Guide	
8	200582-819	-	-	-	x	Thread Guide Screw	
9	212103	-	-	-	x	Feed Dog	
10	236601	-	-	-	x	Throat Plate, 50 Needle Hole	

Parts for Machine No. 212 G 146

For Parts not illustrated and/or not indicated by reference numbers, refer to Machines 212 G140 and 212 G 145

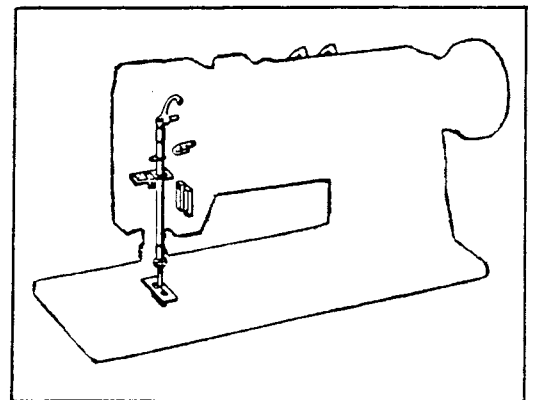
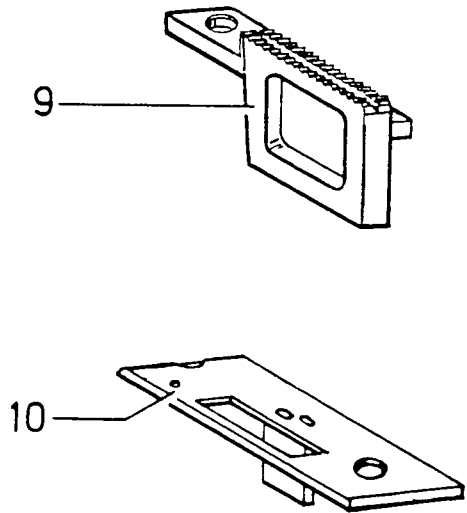
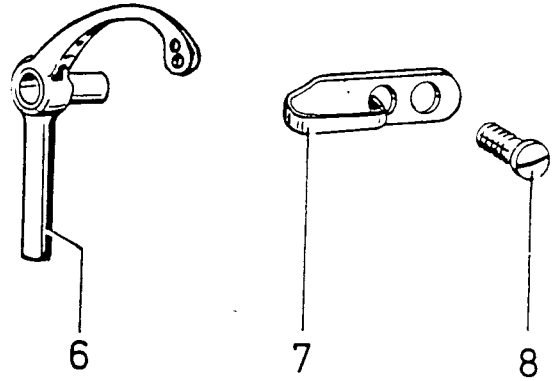
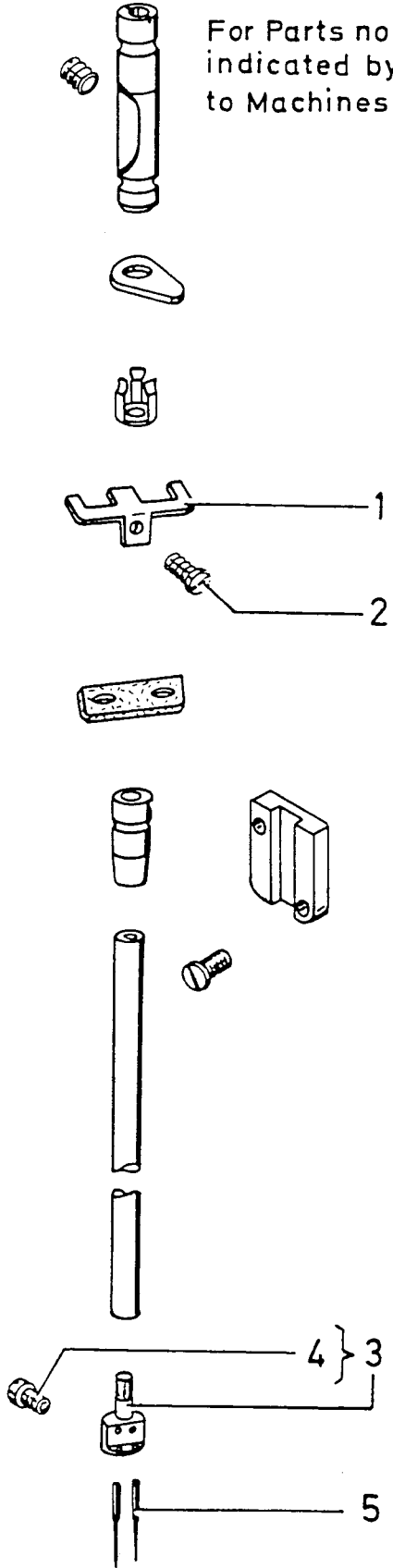

111. Ref. No.		For Class 212 G				Name	Components
Part No.	140	141	145	146			
1	267336	-	-	-	x	Tension Bracket Cpl.	201199, 223702, 223703, 223706, 237174, 267315, 350588, Two 200309, Two 204271, Two 223438, Two 223704, Three 201572, Four 244048
2	223703	-	-	-	x	Tension Release Lever	
3	200309-805	-	-	-	x	Tension Release Lever Screw	
4	223702	-	-	-	x	Tension Bracket with	Two 201224, Two 236060
5	236060	-	-	-	x	Tension Disc Position Pin (2)	
6	201224-850	-	-	-	x	Tension Stud (2)	
7	244048	-	-	-	x	Tension Disc (4)	
8	204271	-	-	-	x	Tension Release Washer (2)	3
9	223438	-	-	-	x	Tension Spring (2)	
10	201572-819	-	-	-	x	Tension Thumb Nut (3)	
11	201199-806	-	-	-	x	Thread Controller Stud	
12	237174	-	-	-	x	Thread Controller Spring	
13	267315	-	-	-	x	Thread Controller Spring Stop	
14	223706	-	-	-	x	Thread Controller Disc	
15	350588-819	-	-	-	x	Thread Controller Disc Screw	
16	223704	-	-	-	x	Tension Release Plunger	

Parts for Machine No. 212 G 146

For Parts not illustrated and/or not indicated by reference numbers, refer to Machines 212 G 140 and 212 G 145

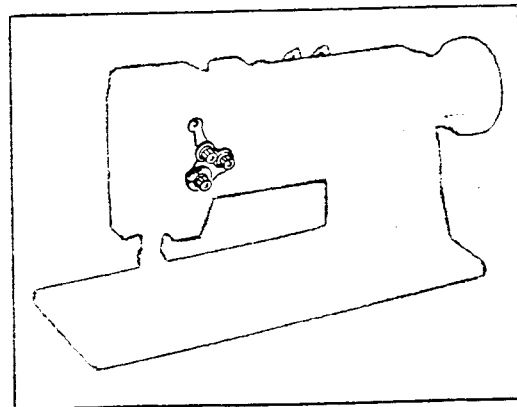
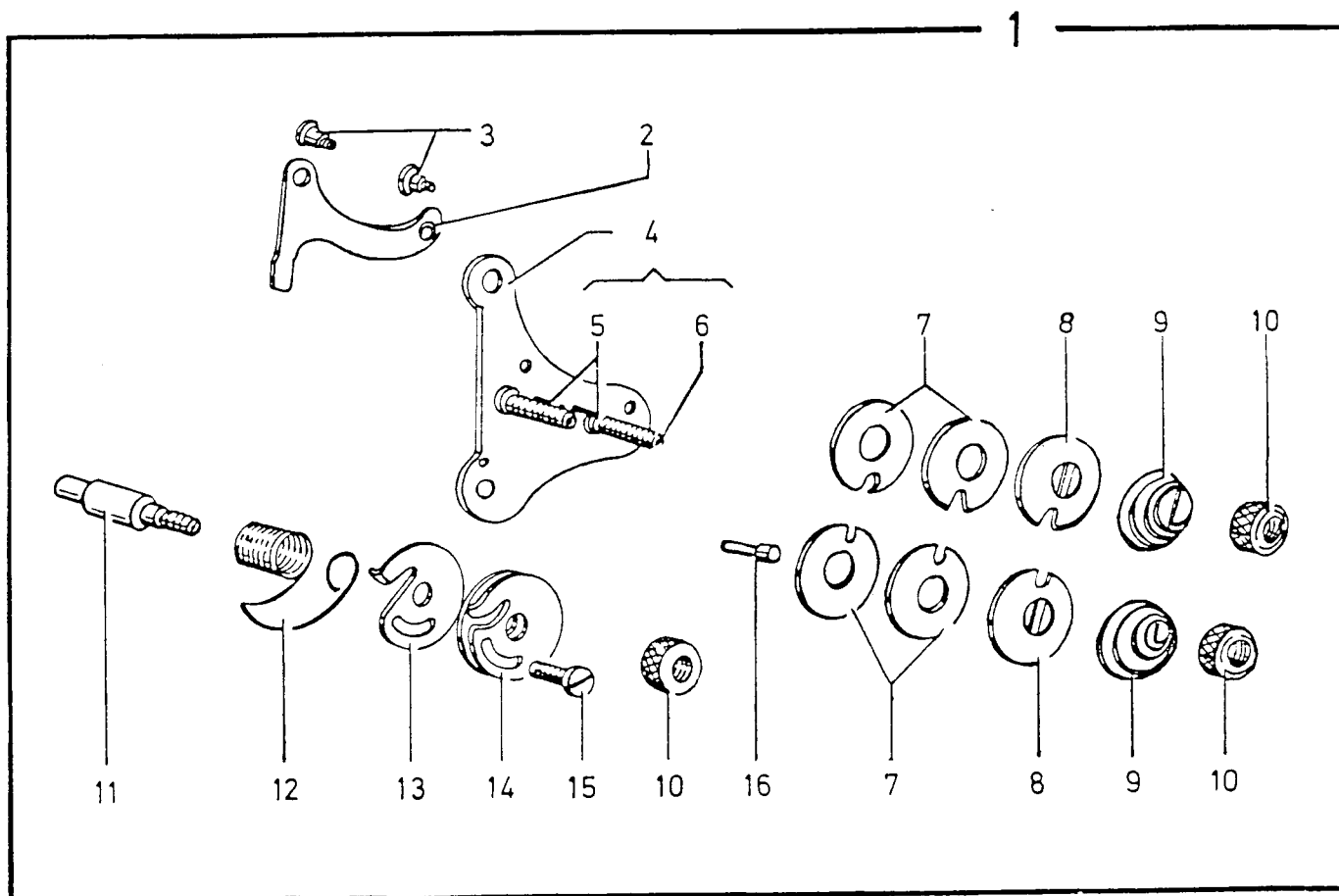

11. ef. o.	For Class 212 G					Name	Components
	Part No.	140	141	145	146		
1	267329	-	-	-	x	Hook Saddle (Right) with	200110, 267327, 267351, 508279
2	267327	-	-	-	x	Hook and Bobbin Case Cpl.	236854, 267356
3	267351	-	-	-	x	Bobbin Case Opener	
4	200110-804	-	-	-	x	Bobbin Case Opener Screw	
5	508279	-	-	-	x	Hook Saddle (Right) Cpl.	200374, 200378, 200388, 244084, 244704, 267053, 267166, 267167, 267172, 267194, 267198, 267200, 267212, 267215, 267248, 267365, 267366, 350564, Two 200089, Two 200135, Two 267361, Eight 200061
6	267361	-	-	-	x	Hook Ball Bearing Retainer (2)	
7	200089-819	-	-	-	x	Hook Ball Bearing Screw (2)	
8	267053	-	-	-	x	Hook Ball Bearing	
9	267166	-	-	-	x	Bobbin Case Opener Crank	
10	200135-805	-	-	-	x	Bobbin Case Opener Link Cap Screw	
11	267172	-	-	-	x	Bobbin Case Opener Link (Right)	
12	267167	-	-	-	x	Bobbin Case Opener Crank Hinge Stud (Right)	
13	350564-805	-	-	-	x	Hook Saddle Oil Regulating Screw	
14	244084	-	-	-	x	Feed Driving Rock Shaft Bushing (Right) Pinch Screw Set Screw Packing (Fibre)	
15	200378-803	-	-	-	x	Hook Saddle Oil Regulating Screw Check Screw	
16	200374-830	-	-	-	x	Bobbin Case Opener Crank Hinge Stud (Right) Set Screw	
17	200388-803	-	-	-	x	Bobbin Case Opener Crank Hinge Stud (Right) Set Screw Check Screw	
18	267248	-	-	-	x	Hook Driving Pinion Thrust Bearing	
19	267198	-	-	-	x	Hook Saddle Oil Gauge Sleeve with	267277
20	267277	-	-	-	x	Hook Saddle Oil Strainer	
21	267200	-	-	-	x	Hook Saddle Oil Reservoir (Right)	
22	267212	-	-	-	x	Hook Saddle Oil Reservoir Gasket	
23	200061-833	-	-	-	x	Hook Saddle Oil Reservoir Screw (8)	
24	267194	-	-	-	x	Hook Saddle (Right) with	200185, 267367, 267370, 267371
25	267367	-	-	-	x	Hook Shaft Bushing (Right)	
26	267370	-	-	-	x	Bobbin Case Opener Driving Cam Shaft Bushing (Lower)	
27	200185-804	-	-	-	x	Hook Saddle Oil Stop Screw	
28	267371	-	-	-	x	Bobbin Case Opener Driving Cam Shaft Bushing (Upper)	
29	267366	-	-	-	x	Hook Driving Pinion (Spiral) with	Two 350595
30	350595-850	-	-	-	x	Hook Driving Pinion Set Screw (2)	
31	267365	-	-	-	x	Bobbin Case Opener Driving Cam Shaft Gear (Spiral) with	Two 350595
32	350595-850	-	-	-	x	Bobbin Case Opener Driving Cam Shaft Gear Set Screw (2)	
33	244704	-	-	-	x	Bobbin Case Opener Driving Cam Shaft	
34	200135-805	-	-	-	x	Bobbin Case Opener Link Cap Screw	
35	267215	-	-	-	x	Hook Shaft with	270880, 276061
36	276061	-	-	-	x	Hook Shaft Oil Wick Holder	
37	270880	-	-	-	x	Hook Shaft Oil Wick	

Parts for Machine No. 212 G 146

For Parts not illustrated and/or not indicated by reference numbers, refer to Machines 212 G 140 and 212 G 145

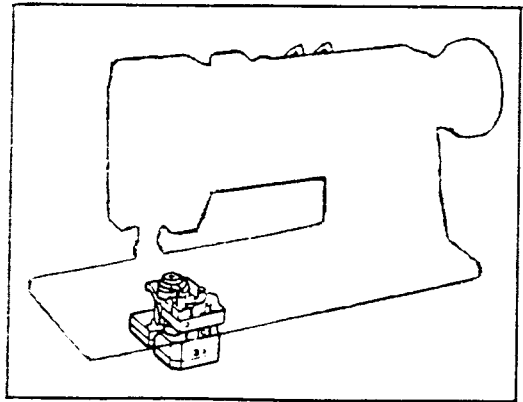
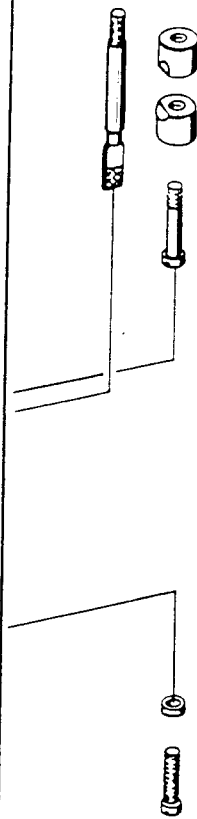
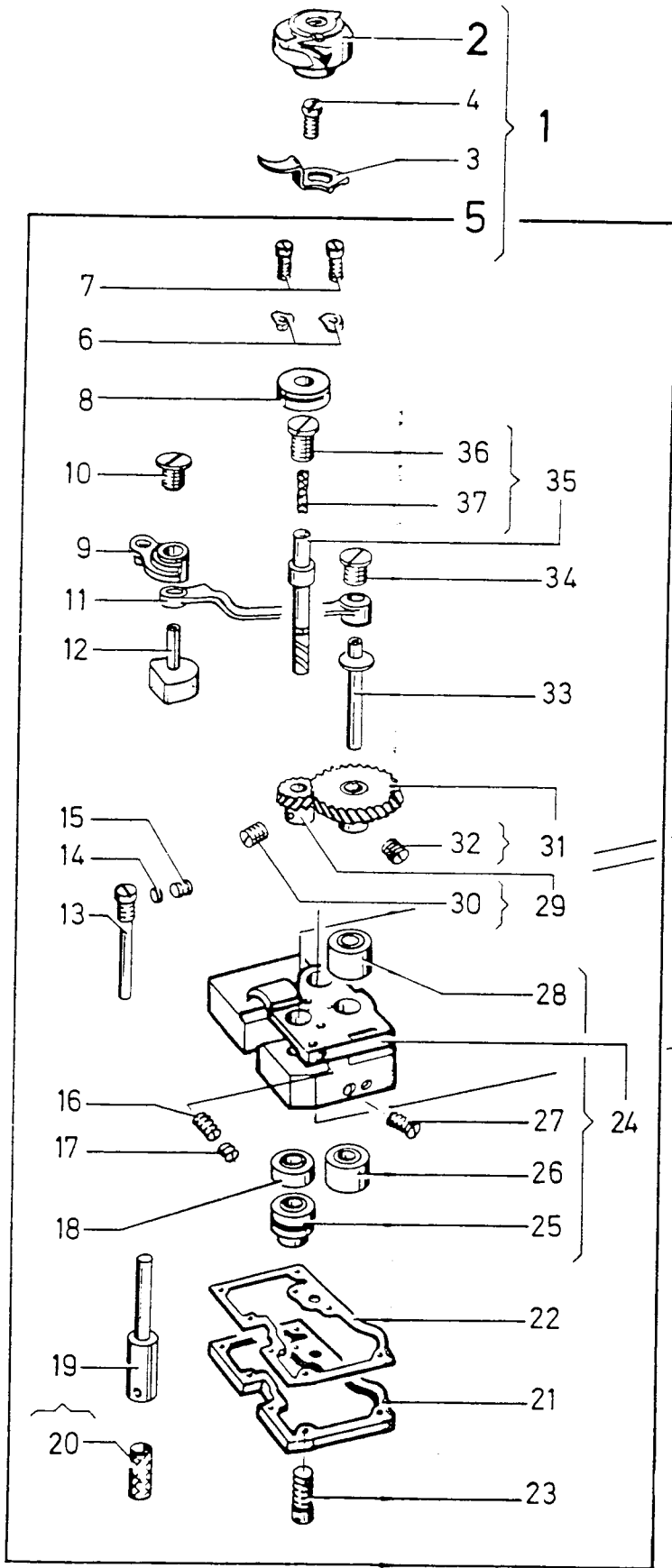

Ill. Ref. No.	Part No.	For Class 212 G				Name	Components
		140	141	145	146		
1	267328	-	-	-	x	Hook Saddle (Left) with	200110, 267327, 267351, 508280 236854, 267356
2	267327	-	-	-	x	Hook and Bobbin Case Cpl.	
3	267351	-	-	-	x	Bobbin Case Opener	
4	200110-804	-	-	-	x	Bobbin Case Opener Screw	
5	508280	-	-	-	x	Hook Saddle (Left) Cpl.	200378, 244084, 244704, 267017, 267053, 267166, 267171, 267193, 267198, 267199, 267212, 267215, 267248, 267365, 267366, 350564, Two 200089, Two 200135, Two 200143, Two 267361, Eight 200061
6	267361	-	-	-	x	Hook Ball Bearing Retainer (2)	
7	200089-819	-	-	-	x	Hook Ball Bearing Screw (2)	
8	267053	-	-	-	x	Hook Ball Bearing	270880, 276061
9	267215	-	-	-	x	Hook Shaft with	
10	276061	-	-	-	x	Hook Shaft Oil Wick Holder	
11	270880	-	-	-	x	Hook Shaft Oil Wick	
12	267171	-	-	-	x	Bobbin Case Opener Link (Left)	
13	200135-805	-	-	-	x	Bobbin Case Opener Link Cap Screw	
14	244704	-	-	-	x	Bobbin Case Opener Driving Cam Shaft	
15	267365	-	-	-	x	Bobbin Case Opener Driving Cam Shaft Gear (Spiral) with	Two 350595
16	350595-850	-	-	-	x	Bobbin Case Opener Driving Cam Shaft Gear Set Screw (2)	
17	267366	-	-	-	x	Hook Driving Pinion (Spiral) with	Two 350595
18	350595-850	-	-	-	x	Hook Driving Pinion Set Screw (2)	
19	267193	-	-	-	x	Hook Saddle (Left) with	200185, 267367, 267370, 267371
20	267371	-	-	-	x	Bobbin Case Opener Driving Cam Shaft Bushing (Upper)	
21	200185-804	-	-	-	x	Hook Saddle Oil Stop Screw	
22	267370	-	-	-	x	Bobbin Case Opener Driving Cam Shaft Bushing (Lower)	
23	267367	-	-	-	x	Hook Shaft Bushing (Left)	
24	267199	-	-	-	x	Hook Saddle Oil Reservoir (Left)	
25	267212	-	-	-	x	Hook Saddle Oil Reservoir Gasket	
26	200061-833	-	-	-	x	Hook Saddle Oil Reservoir Screw (8)	
27	267198	-	-	-	x	Hook Saddle Oil Gauge Sleeve with	267277
28	267277	-	-	-	x	Hook Saddle Oil Strainer	
29	267248	-	-	-	x	Hook Driving Pinion Thrust Bearing	
30	350564-805	-	-	-	x	Hook Saddle Oil Regulating Screw	
31	244084	-	-	-	x	Feed Driving Rock Shaft Bushing (Left) Pinch Screw Set Screw Packing (Fibre)	
32	200378-803	-	-	-	x	Hook Saddle Oil Regulating Screw Check Screw	
33	267017	-	-	-	x	Bobbin Case Opener Crank Hinge Bracket (Left)	
34	200143-819	-	-	-	x	Bobbin Case Opener Crank Hinge Bracket (Left) Screw (2)	
35	267166	-	-	-	x	Bobbin Case Opener Crank	
36	200135-805	-	-	-	x	Bobbin Case Opener Link Cap Screw	

Parts for Machine No. 212 G 146

For Parts not illustrated and/or not indicated by reference numbers, refer to Machines 212 G 140 and 212 G 145

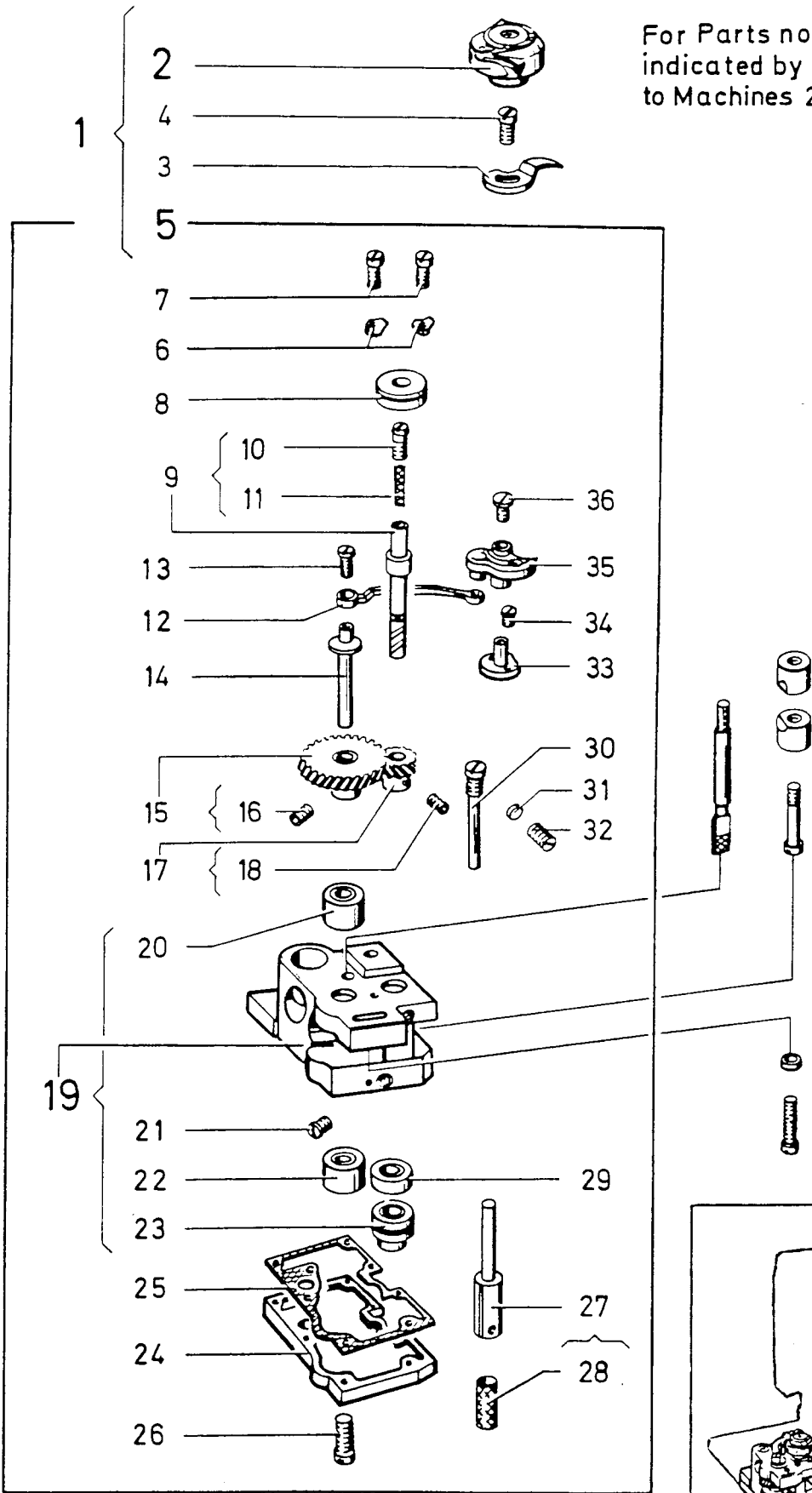

Ill. Ref. No.	Part No.	For Class 212 G				Name	Components
		140	141	145	146		
1	233939	-	-	-	x	Bobbin (2)	236854, 267356
2	267327	-	-	-	x	Hook and Bobbin Case Cpl. (2) with each	
3	236854	-	-	-	x	Bobbin Case Cpl.	*203210, 236853
4	236853	-	-	-	x	Bobbin Case Cap with	200984, 203214, 203215, 241674, 241675, Two 200594, Two 350405
5	203214	-	-	-	x	Bobbin Case Tension Spring	
6	200984-803	-	-	-	x	Bobbin Case Tension Spring Regulating Screw	
7	200594-805	-	-	-	x	Bobbin Case Tension Spring Screw	
8	241675	-	-	-	x	Bobbin Case Oiling Felt Retainer	
9	241674	-	-	-	x	Bobbin Case Oiling Felt	
10	350405	-	-	-	x	Bobbin Case Oiling Felt Retainer Screw (2)	
11	203215	-	-	-	x	Bobbin Case Thread Guide	
12	200594-805	-	-	-	x	Bobbin Case Thread Guide Screw	
*13	203210	-	-	-	x	Bobbin Case Base with	*202056, 203211, 203212, 203213, 203216
14	203216	-	-	-	x	Bobbin Case Washer (Cloth)	
15	203213	-	-	-	x	Bobbin Case Base Latch Spring	
16	203212	-	-	-	x	Bobbin Case Base Latch Plunger	
17	203211	-	-	-	x	Bobbin Case Base Latch	
*18	202056	-	-	-	x	Bobbin Case Base Latch Pin	
19	267356	-	-	-	x	Hook with	267355, 267358, 267359, 267360, 350574, Two 200591, Two 201253, Two 201409, Two 140434
20	267355	-	-	-	x	Hook Sewing with	
21	140434-833	-	-	-	x	Hook Set Screw (2)	
22	267360	-	-	-	x	Hook Thread Guard	
23	200591-819	-	-	-	x	Thread Guide Screw (2)	
24	267359	-	-	-	x	Hook Needle Guard	
25	201409-806	-	-	-	x	Hook Needle Guard Screw (2)	
26	350574-806	-	-	-	x	Hook Height Adjusting Screw	
27	267358	-	-	-	x	Hook Gib	
28	201253-806	-	-	-	x	Hook Gib Screw (2)	

Parts marked with an asterisk (*) are furnished only when repairs are made at the factory.

Parts for Machine No. 212 G 146

For Parts not illustrated and/or not indicated by reference numbers, refer to Machines 212 G 140 and 212 G 145

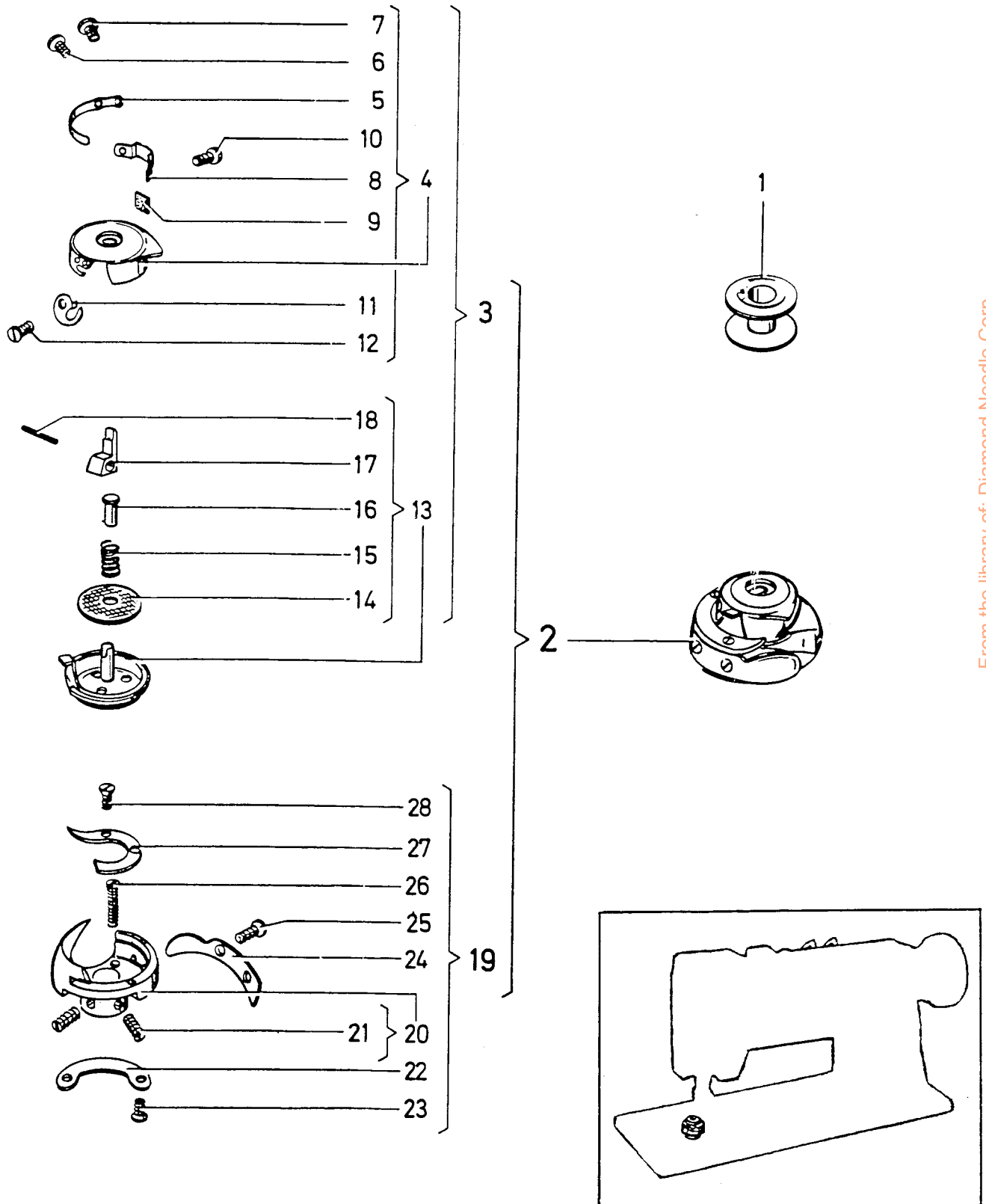

Ill. Ref. No.	Part No.	For Class 212 G				Name	Components
		140	141	145	146		
1	267326	-	-	-	x	Face Plate and Thread Lubricator Cpl.	001623, 201738, 201750, 244735 to 244743, 267323, 267325, Two 244746, Six 201402
2	244741	-	-	-	x	Thread Lubricator Oil Socket Plunger Release Lever	
3	267323	-	-	-	x	Thread Lubricator Oil Socket Plunger Release Lever Pin	
4	201750-819	-	-	-	x	Thread Lubricator Oil Socket Plunger Adjusting Nut	
5	244742	-	-	-	x	Thread Lubricator Oil Socket Plunger Spring	
6	244739	-	-	-	x	Thread Lubricator Oil Socket Plunger	
7	244740	-	-	-	x	Thread Lubricator Oil Socket Plunger Oil Seal (Oil)	
8	001623-819	-	-	-	x	Thread Lubricator Oil Socket Lock Nut	
9	244748	-	-	-	x	Thread Lubricator Oil Adjusting Nut Retainer	
10	267325	-	-	-	x	Face Plate	
11	244736	-	-	-	x	Thread Lubricator Oil Reservoir Cover Gasket (On Face Plate)	
12	244735	-	-	-	x	Thread Lubricator Oil Reservoir Cover (On Face Plate)	
13	201402-819	-	-	-	x	Thread Lubricator Oil Reservoir Cover Screw (6)	
14	244738	-	-	-	x	Thread Lubricator Oil Socket Lock Nut Washer	
15	244746	-	-	-	x	Thread Lubricator Oil Socket Oil Seal (Rubber) (2)	
16	244737	-	-	-	x	Thread Lubricator Oil Socket	
17	244743	-	-	-	x	Thread Lubricator Oil Tube	
18	201738-819	-	-	-	x	Thread Lubricator Oil Tube Nut	
20	244734	-	-	-	x	Thread Lubricator Oil Pad Holder Cpl.	241765, 244744, 263554, Two 200143
21	244744	-	-	-	x	Thread Lubricator Plate	
22	200143-819	-	-	-	x	Thread Lubricator Oil Pad Holder Screw (2)	
23	241765	-	-	-	x	Thread Lubricator Oil Pad (Felt)	
24	263554	-	-	-	x	Thread Lubricator Oil Pad Holder	
25	200582-819	-	-	-	x	Thread Lubricator Plate Screw (2)	

Parts for Machine No. 212 G 146

For Parts not illustrated and/or not indicated by reference numbers, refer to Machines 212 G 140 and 212 G 145

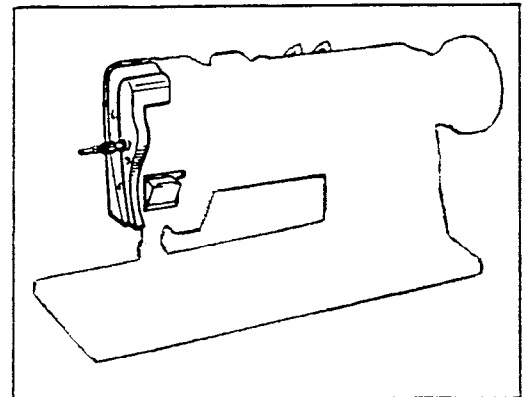
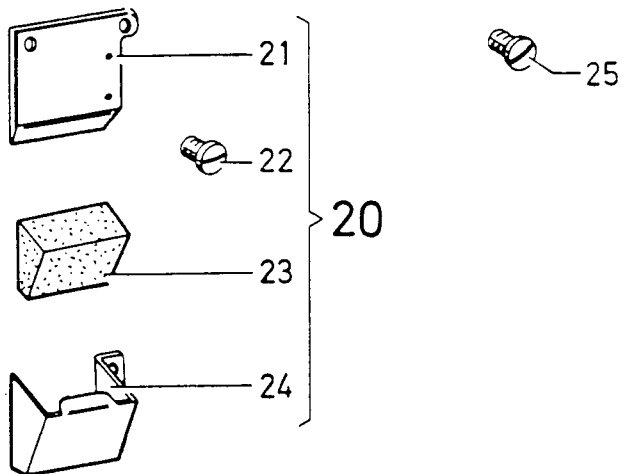
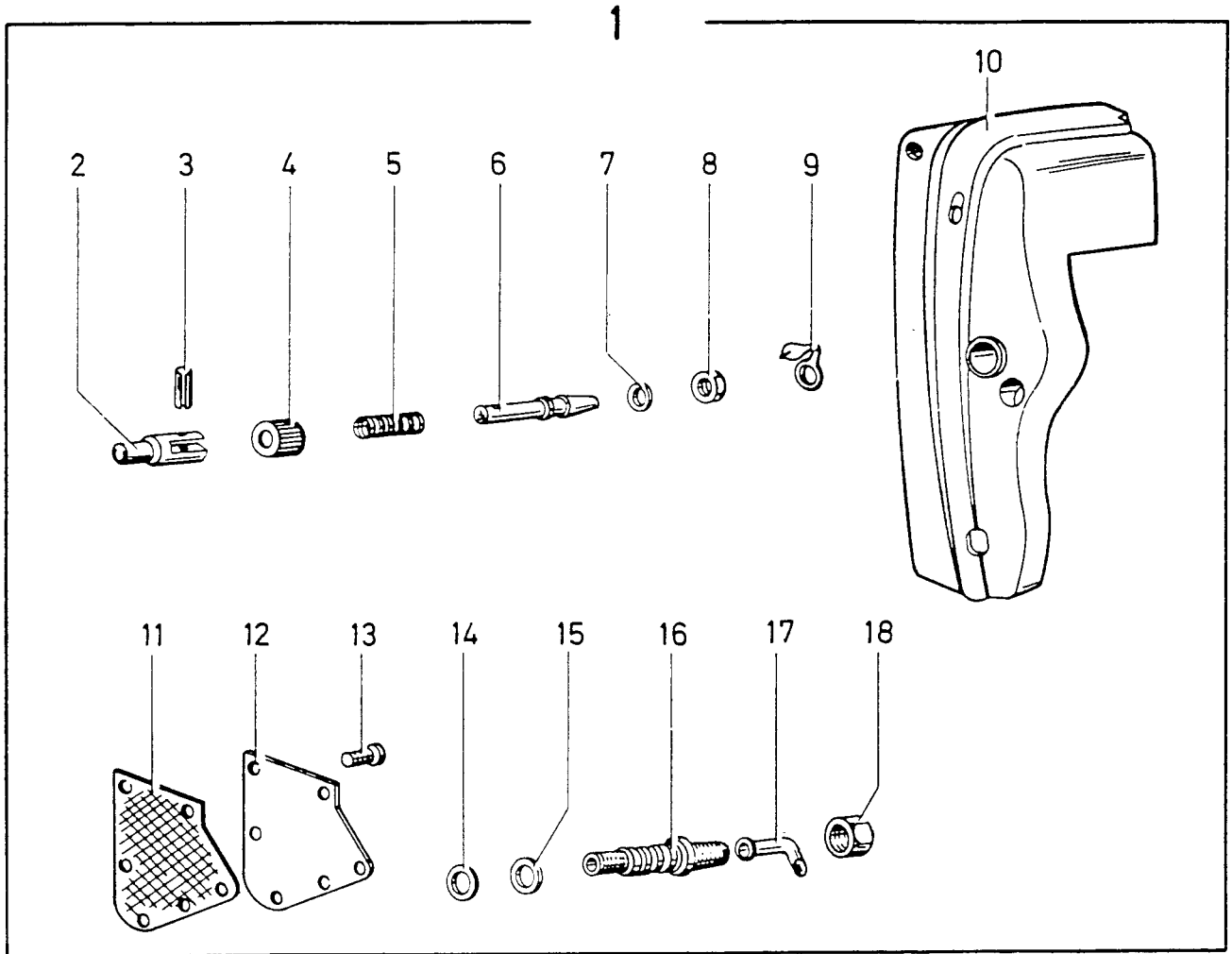

For Class 212 G					Name	Components		
1.	f.	Part No.	140	141			145	146
		267335	-	-	-	x	Roller Presser and Bar Cpl.	200082, 200117, 201071, 202558, 203427, 204495, 229325, 229328, 229371, 229745, 235087, 235088, Two 200141
		204495	-	-	-	x	Roller Presser Bar	
		200117-805	-	-	-	x	Roller Presser Arm Bracket Position Collar Position Screw	200362
		235088	-	-	-	x	Roller Presser Arm Bracket Position Collar with	
		200362-803	-	-	-	x	Roller Presser Arm Bracket Position Collar Set Screw	
		235087	-	-	-	x	Roller Presser Arm Bracket	
		201071-806	-	-	-	x	Roller Presser Needle Guard (Front) Screw	
		229745	-	-	-	x	Roller Presser Arm Shim 1/32 Inch Thick	
		229325	-	-	-	x	Roller Presser Needle Guard (Front)	
		200141-806	-	-	-	x	Roller Presser Arm Bracket Spring Stop Screw (2)	
		202558	-	-	-	x	Roller Presser Arm Bracket Spring	
		229371	-	-	-	x	Roller Presser Arm Bracket Spring Stop and (Back) Needle Guard Holder with	229370, 200350, 201317, 226220
		200350-819	-	-	-	x	Roller Presser Arm Bracket Spring Stop and (Back) Needle Guard Holder Adjusting Screw	
		201317-806	-	-	-	x	Roller Presser Needle Guard (Back) Clamp Screw	
		226220	-	-	-	x	Roller Presser Needle Guard (Back) Clamp Screw Washer	
		229370	-	-	-	x	Roller Presser Arm Bracket Spring Stop and (Back) Needle Guard Holder	
		229328	-	-	-	x	Roller Presser Needle Guard (Back)	
		200082-804	-	-	-	x	Roller Presser Arm Screw	201928, 203426
		203427	-	-	-	x	Roller Presser Arm with	
		203426	-	-	-	x	Roller Presser Arm	001528, 001766, 050553, Twenty-four 016232
		201928	-	-	-	x	Roller Presser 1 1/4 Inch Diam. with	
		001528-819	-	-	-	x	Roller Presser Hinge Screw Nut	
		001766-803	-	-	-	x	Roller Presser Ball Cone	
		016232	-	-	-	x	Roller Presser Ball 3/32 Inch Diameter (24)	
		050553-803	-	-	-	x	Roller Presser Hinge Screw	

Parts for Machine No. 212 G 146

For Parts not illustrated and/or not indicated by reference numbers, refer to Machines 212 G 140 and 212 G 145

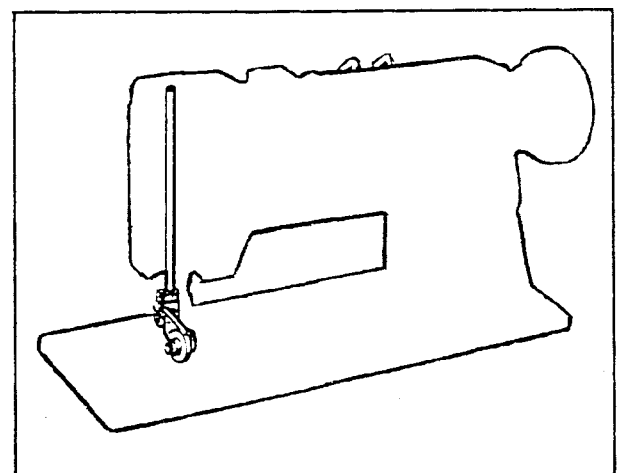
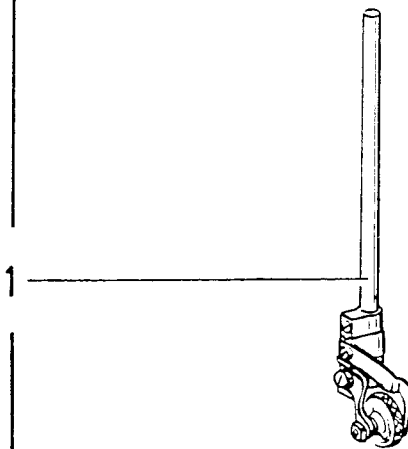
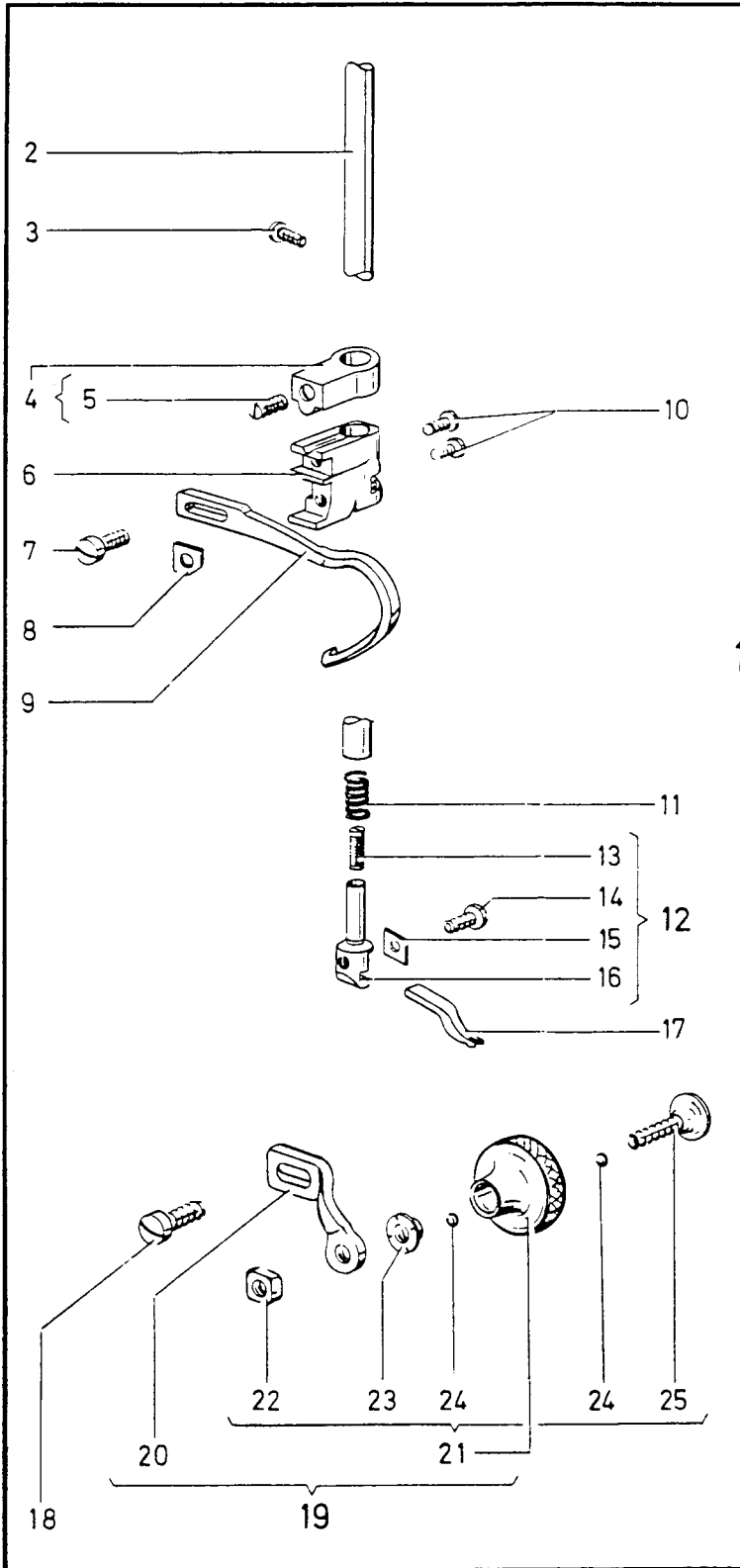

Ill. Ref. No.	Part No.	For Class 212 G				Name	Components
		140	141	145	146		
1	228888	x	x	x	x	Drip Pan (Plastic) Cpl.	228883, 228887 Five 350708
2	228887	x	x	x	x	Drip Pan	
3	350708	x	x	x	x	Drip Pan (Plastic) Screw Nail (5)	
4	228883	x	x	x	x	Drip Pan Drain Jar	
5	228904	x	x	x	x	Knee Lifter Rock Lever Cpl.	228318, 228364, 228365, 228751, 267374
6	228751	x	x	x	x	Knee Lifter Rock Lever Bracket with	228363, 228367, 228386, 228455, 228707, 228752
7	228363	x	x	x	x	Knee Lifter Rock Lever Hinge Pin	
8	228752	x	x	x	x	Knee Lifter Rock Lever with	Two 350231
9	350231-803	x	x	x	x	Knee Lifter Rock Lever Extension Set Screw and Knee Lifter Rock Lever Knee Plate Arm Set Screw (2)	
10	228455	x	x	x	x	Knee Lifter Rock Lever Position Spring	
11	228386	x	x	x	x	Knee Lifter Rock Lever Spring	
12	228367	x	x	x	x	Knee Lifter Rock Lever Stop Stud	200347,
13	228707	x	x	x	x	Knee Lifter Rock Lever Bracket with	Three wood screws 7/8 in. No. 12
14	200347-830	x	x	x	x	Knee Lifter Rock Lever Stop Stud Set Screw	
15	-----	x	x	x	x	Knee Lifter Rock Lever Wood Screw 7/8 Inch No. 12 (3)	
16	228364	x	x	x	x	Knee Lifter Rock Lever Knee Plate with	350231
17	350231-803	x	x	x	x	Knee Lifter Rock Lever Knee Plate Set Screw	
18	228318	x	x	x	x	Knee Lifter Rock Lever Knee Plate Arm	
19	228365	x	x	x	x	Knee Lifter Rock Lever Rod	
20	267374	x	x	x	x	Knee Lifter Rock Lever Extension with	200530
21	200530-803	x	x	x	x	Knee Lifter Rock Lever Rod Set Screw	
22	224413	x	x	x	x	Knee Lifter Connection Lever Lifting Rod Roller Bracket Cpl.	200270, 224411, 224412
23	224412	x	x	x	x	Knee Lifter Connection Lever Lifting Rod Roller Bracket with	200113
24	200113-806	x	x	x	x	Knee Lifter Connection Lever Lifting Rod Roller Bracket Set Screw	
25	224411	x	x	x	x	Knee Lifter Connection Lever Lifting Rod Roller	
26	200270-819	x	x	x	x	Knee Lifter Connection Lever Lifting Rod Roller Hinge Screw	

ACCESSORIES
FOR

- 212 G 140
- 212 G 141
- 212 G 145
- 212 G 146

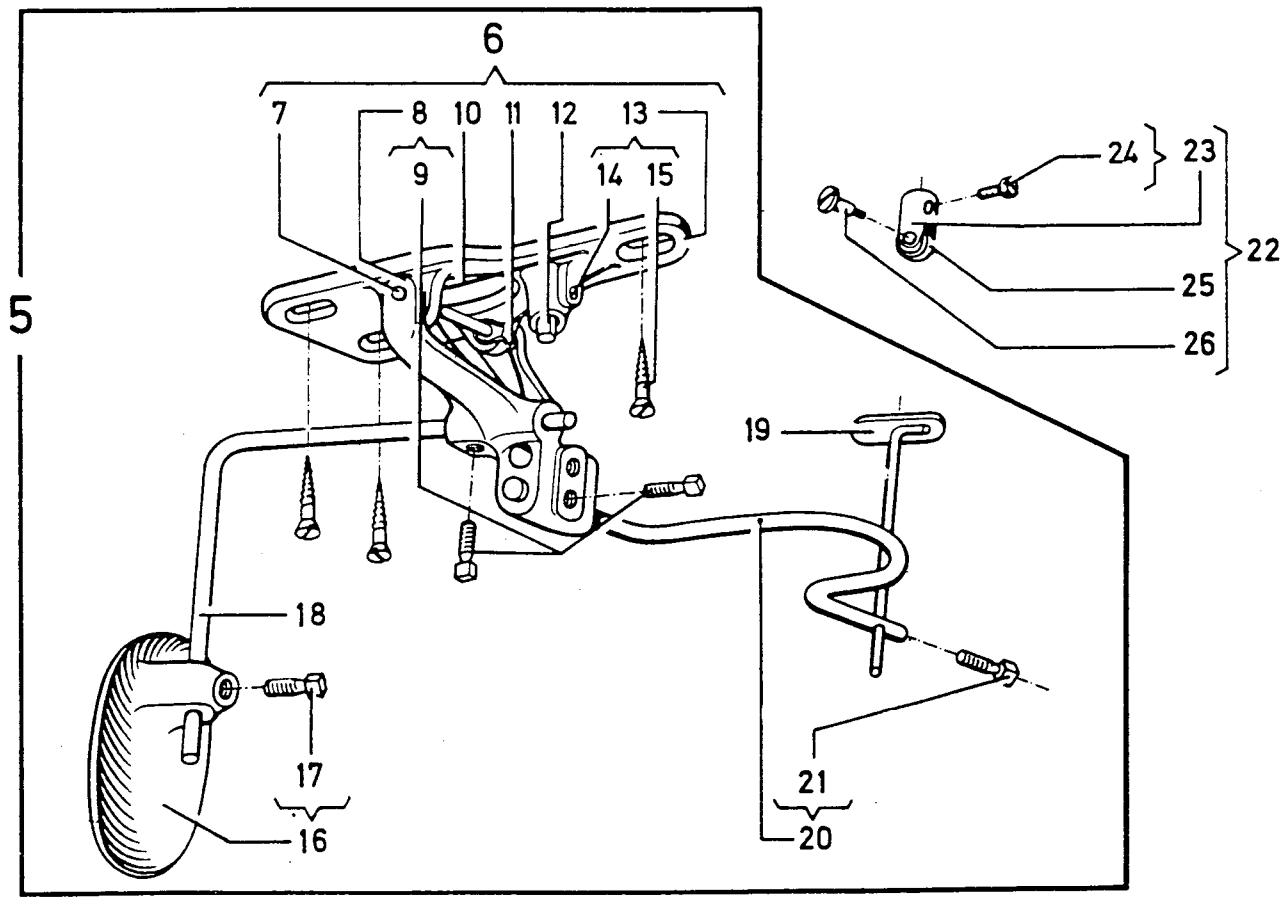
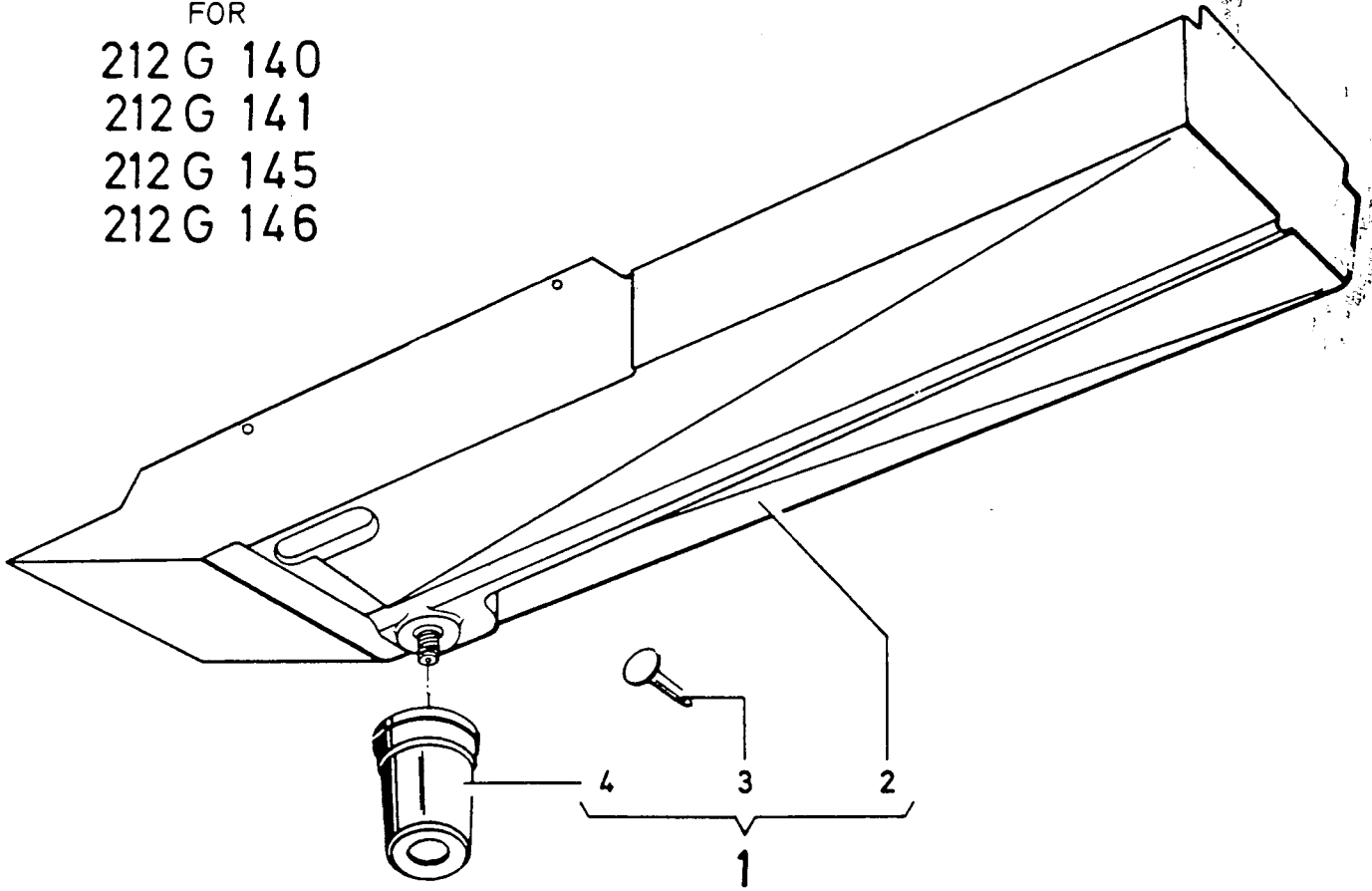

From the library of: Diamond Needle Corp

Ill. Ref. No.	Part No.	For Class 212 G				Name	Components
		140	141	145	146		
1	228777	x	x	x	x	Thread Unwinder Cpl. (For three Spools)	228765 to 228768, 228771, 228774, Three each 150203, 228764, 228769 and wood screws 7/8 in. No. 12
2	228769	x	x	x	x	Thread Unwinder Thread Guide	
3	228771	x	x	x	x	Thread Unwinder Thread Guide Holder (For three Guides)	
4	228774	x	x	x	x	Thread Unwinder Thread Guide Rod	
5	228764	x	x	x	x	Thread Unwinder Spool Pin (3)	
6	150203	x	x	x	x	Thread Unwinder Spool Rest Cushion (Felt) (3)	
7	228766	x	x	x	x	Thread Unwinder Spool Rest (For two Spools) (Flat) with	201254
8	201254-803	x	x	x	x	Thread Unwinder Spool Rest Set Screw	
9	228765	x	x	x	x	Thread Unwinder Spool Rest (For one Spool) (Flat) with	201254
10	201254-803	x	x	x	x	Thread Unwinder Spool Rest Set Screw	
11	228768	x	x	x	x	Thread Unwinder Spool Stand	
12	-----	x	x	x	x	Thread Unwinder Wood Screw 7/8 Inch No. 12 (3)	
13	228767	x	x	x	x	Thread Unwinder Spool Rest Rod	
15	120342	x	x	x	x	Oiler (Copper Plated) with	120343
16	120343	x	x	x	x	Oiler Spout 3 1/2 Inch Long	
17	202258	x	x	x	x	Bed Hinge Connection (2)	
18	200570-805	x	x	x	x	Bed Hinge Connection Screw (4)	
19	200157-805	x	x	x	x	Attachment Screw	
20	041400	x	x	x	x	Machine Rest Pin (Wood)	
21	228476	x	x	x	x	Screw Driver	
22	225498	x	x	x	x	Screw Driver (7 1/4 Inch Long)	
23	225554	x	x	x	x	Wrench	
24	267242	x	x	x	x	Wrench (3/32 Inch Hex.)	
25	001901-12-2	x	-	-	-	Needle (2)	
26	001901-14-2	-	x	x	-	Needle (10)	

ACCESSORIES

FOR

212 G 140

212 G 141

212 G 145

212 G 146

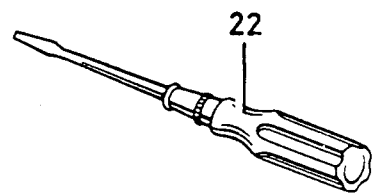
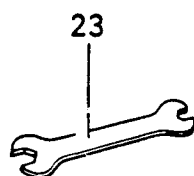
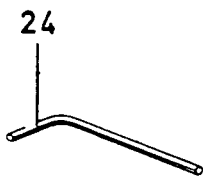
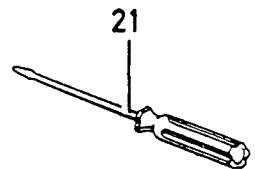
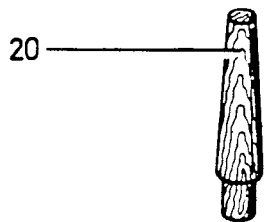
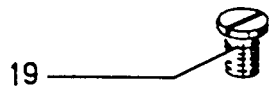
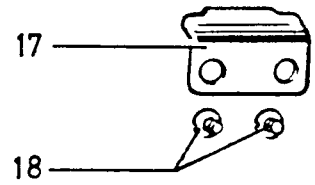
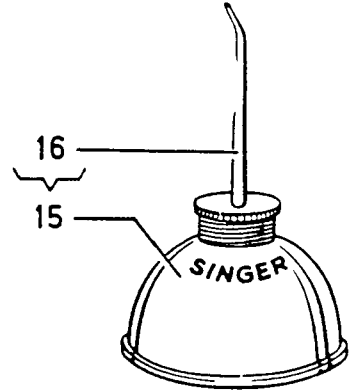
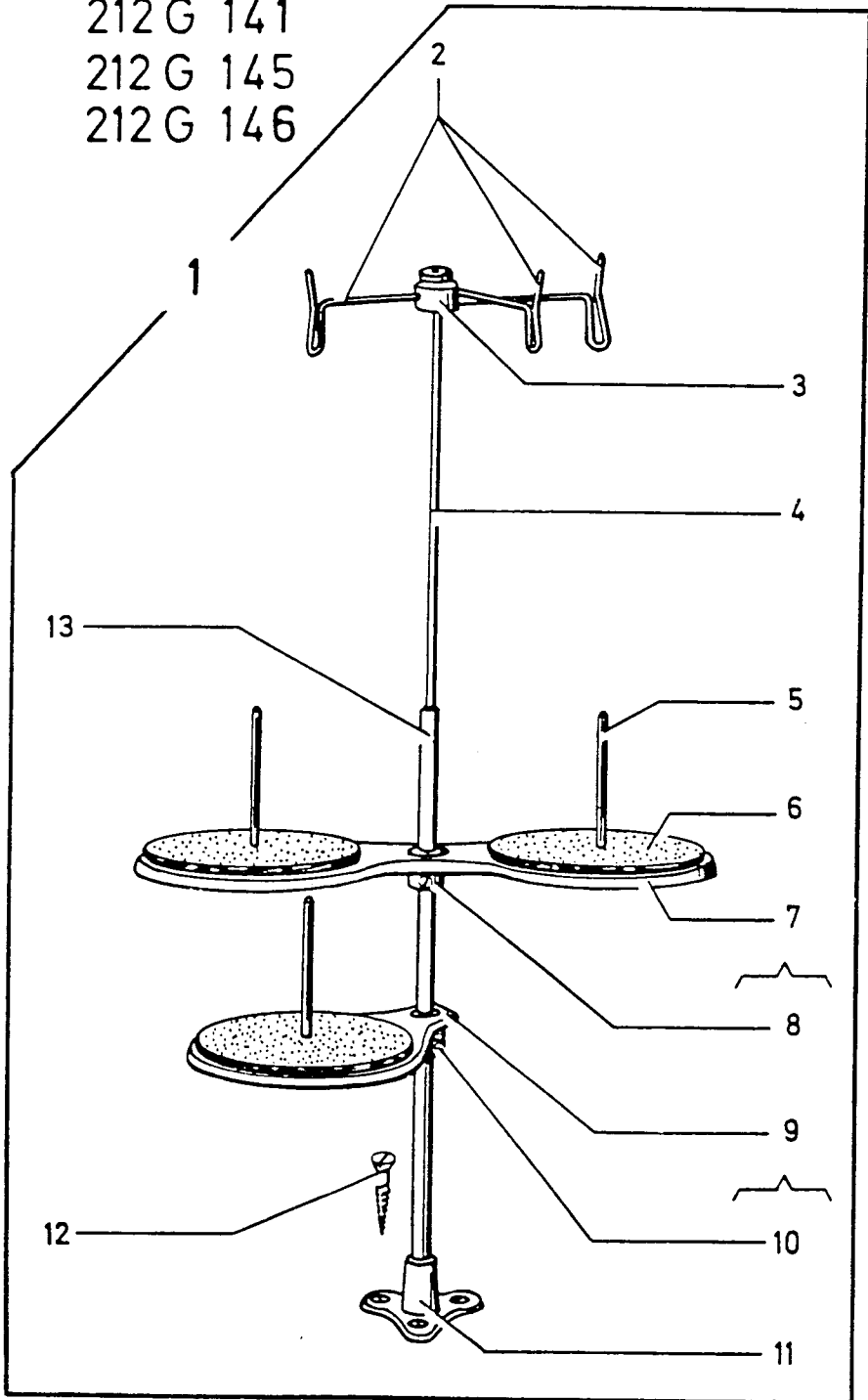

For Class 212 G						Name	Components
Ill. Ref. No.	Part No.	140	141	145	146		
1	259462	x	x	x	x	Universal Bobbin Winder Cpl.	200056, 200082, 200113, 200299, 202478, 225381, 225444, 225453 to 225456, 225458, 225462, 228026, 259428, 259429, 259662, 259930, Two each 225459 and wood screws 3/4 in. No. R.H.B.
2	225462	x	x	x	x	Bobbin Winder Tension Bracket Cpl.	013710, 201572, 225461, Two 002102
3	201572-819	x	x	x	x	Bobbin Winder Tension Stud Thumb Nut	
4	013710	x	x	x	x	Bobbin Winder Tension Spring	
5	002102	x	x	x	x	Bobbin Winder Tension Disc (2)	
6	225461	x	x	x	x	Bobbin Winder Tension Bracket with	201499
7	201499-819	x	x	x	x	Bobbin Winder Tension Stud	
8	259662	x	x	x	x	Bobbin Winder and Tension Bracket Base	
9	228026	x	x	x	x	Bobbin Winder Tension Bracket Screw Washer	
10	200082-804	x	x	x	x	Bobbin Winder Tension Bracket Screw	
11	225456	x	x	x	x	Bobbin Winder Frame Spring Plunger	
12	225455	x	x	x	x	Bobbin Winder Frame Spring	
13	225454	x	x	x	x	Bobbin Winder Frame Hinge Pin	
14	225459	x	x	x	x	Bobbin Winder Stop Latch Thumb Lever Hinge and Joint Stud (2)	
15	259429	x	x	x	x	Bobbin Winder Brake Clamp	
16	259428	x	x	x	x	Bobbin Winder Brake (Leather)	
17	200113-850	x	x	x	x	Bobbin Winder Brake Clamp Screw	
18	225458	x	x	x	x	Bobbin Winder Stop Latch Thumb Lever	
19	225444	x	x	x	x	Bobbin Winder Stop Latch	
20	200056-805	x	x	x	x	Bobbin Winder Stop Latch Screw	
21	200299-819	x	x	x	x	Bobbin Winder Stop Latch Trip Lever Hinge Screw	
22	259930	x	x	x	x	Bobbin Winder Pulley with	000624
23	000624-833	x	x	x	x	Bobbin Winder Pulley Set Screw	
24	225453	x	x	x	x	Bobbin Winder Frame with	244071, 259660
25	244071	x	x	x	x	Bobbin Winder Frame Oil Packing (Wick)	
26	259660	x	x	x	x	Bobbin Winder Frame Oil Well Washer	
27	225381	x	x	x	x	Bobbin Winder Spindle	
28	202478	x	x	x	x	Bobbin Winder Stop Latch Trip Lever	
29	-----	x	x	x	x	Bobbin Winder Wood Screw (3/4 Inch No. 12 R.H.B.) (2)	
30	244750	x	x	x	-	Bobbin (4)	
31	233939	-	-	-	x	Bobbin (4)	
32	004822	-	-	-	x	Roller Presser Hinge Screw Nut Wrench	
33	001740-11-1	-	-	-	x	Needle (6)	
34	001740-13-1	-	-	-	x	Needle (4)	

ACCESSORIES

FOR

212 G 140

212 G 141

212 G 145

212 G 146

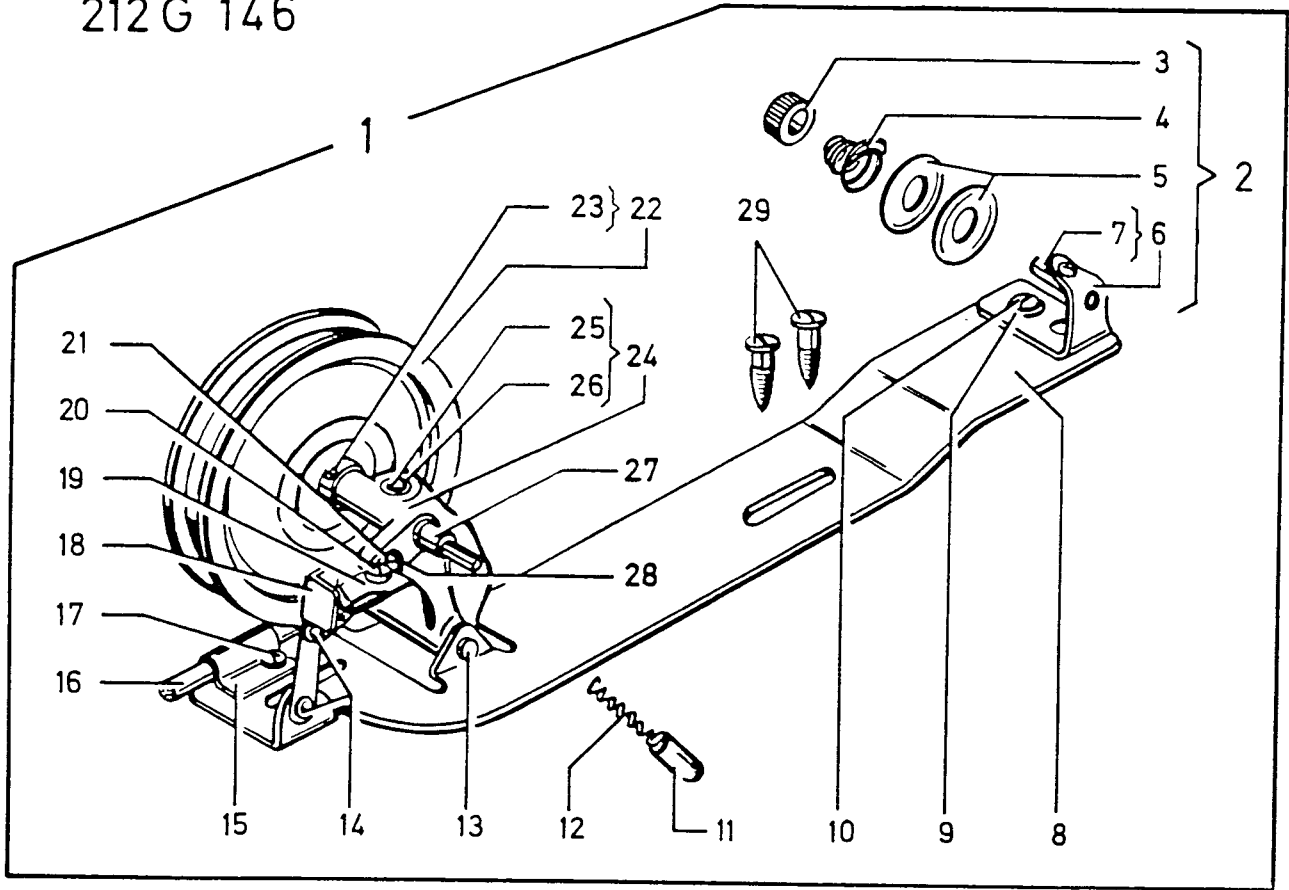

From the library of: Diamond Needle Corp

212 G 140

212 G 141

212 G 145

212 G 146

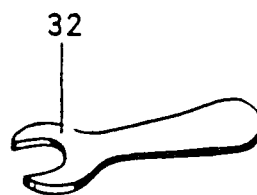

NUMERICAL LIST OF PARTS

Part No.	Page No.	Part No.	Page No.	Part No.	Page No.
237	6	200089	16, 18, 36,	200388	2, 16, 36
624	50		38	200394	24
691	6, 24	200106	10	200530	46
1528	44	200110	16, 18, 36,	200570	48
1623	42		38	200575	24
Cat.		200113	12, 46, 50	200580	8
1740-11-1	50	200117	44	200582	8, 14, 32,
Cat.		200126	6		42
1740-13-1	32, 50	200132	12, 14	200587	4
1766	44	200133	6	200591	20, 40
Cat.		200135	16, 18, 36,	200594	20, 40
1901-12-2	2, 48		38	200653	12
Cat.		200141	2, 32, 44	200738	12
1901-14-2	22, 48	200143	18, 38, 42	200904	30, 32
2102	50	200157	48	200948	12
4822	50	200159	14	200975	12
13710	14, 28, 50	200161	6	200978	14
16232	44	200173	10, 26	200984	40
41400	48	200176	4	201016	20
50553	44	200185	16, 18, 36,	201071	44
120342	48		38	201199	14, 28, 34
120343	48	200247	24	201220	8, 10
140434	20, 40	200262	12	201224	14, 28, 34
141566	2, 22, 26	200270	46	201253	20, 40
141567	2, 22, 26	200274	24	201254	8, 26, 48
150203	48	200299	50	201317	44
200001	16, 18	200309	14, 28, 34	201341	6
200006	16, 18	200333	2	201402	42
200019	24	200336	10, 26	201409	20, 40
200025	22	200337	14	201499	50
200029	4, 10, 24	200341	2	201517	4
200034	4	200347	46	201518	10, 26
200040	10, 24, 26	200350	44	201525	6
200047	6, 24	200352	12, 30	201529	24
200051	30	200362	44	201531	24
200054	10, 30	200363	2	201535	10, 26
200056	50	200364	24	201572	14, 28, 34,
200061	16, 18, 36,	200374	2, 16, 36		50
	38	200378	2, 16, 18,	201738	42
200072	2		36, 38	201750	42
200074	12	200382	8, 24	201829	24
200082	44, 50	200383	2, 10	201928	44
200086	12, 30	200386	6, 24	202056	20, 40

NUMERICAL LIST OF PARTS

Part No.	Page No.	Part No.	Page No.	Part No.	Page No.
202253	2, 8, 26	223704	14, 28, 34	228752	46
202254	8, 10	223706	14, 28, 34	228764	48
202258	48	223798	12	228765	48
202277	4	223799	12	228766	48
202330	2	223811	6	228767	48
202337	12	223812	6	228768	48
202338	12	223847	8	228769	48
202399	2	223852	6	228771	48
202401	12	223853	6	228774	48
202478	50	224031	6	228777	48
202552	2	224040	14	228883	46
202558	44	224144	6	228887	46
202625	10	224411	46	228888	46
202671	12	224412	46	228904	46
203210	40	224413	46	229102	30
203211	40	225381	50	229325	44
203212	40	225444	50	229328	44
203213	40	225453	50	229370	44
203214	40	225454	50	229371	44
203215	40	225455	50	229745	44
203216	20, 40	225456	50	230795	12
203426	44	225458	50	232244	24
203427	44	225459	50	233939	40, 50
203473	20	225461	50	235087	44
203474	20	225462	50	235088	44
203648	20	225498	48	235706	2
204271	14, 28, 34	225554	48	235871	30
204329	2	225585	16, 18	235901	30
204495	44	225837	10, 26	236060	14, 28, 34
206608	12	226220	44	236061	6
207072	12	227227	12	236081	20
208566	12	228026	50	236082	20
210949	12	228318	46	236083	20
212103	32	228363	46	236403	26
213479	6	228364	46	236405	26
223309	12	228365	46	236601	32
223438	34	228367	46	236853	40
223639	10	228386	46	236854	40
223650	10	228455	46	237174	28, 34
223655	10, 26	228476	48	240067	12
223702	14, 28, 34	228707	46	240068	12
223703	14, 28, 34	228751	46	240227	24

NUMERICAL LIST OF PARTS

Part No.	Page No.	Part No.	Page No.	Part No.	Page No.
240245	8	259429	50	267199	18, 38
240550	22	259462	50	267200	16, 36
240564	12	259660	50	267212	16, 18, 36, 38
240574	24	259662	50	267215	16, 18, 36, 38
240589	24	259930	50	267220	6
241360	14	263093	8	267221	2
241674	40	263554	42	267224	2
241675	40	263567	8	267228	4
241763	8	264714	2	267229	4
241765	42	265791	32	267228	4
243744	10	267017	18, 38	267229	4
244048	14, 28, 34	267031	10	267230	4
244071	2, 24, 50	267032	10	267231	4
244084	16, 18, 36, 38	267033	8	267232	4
244704	16, 18, 36, 38	267034	10	267233	4
244705	6	267053	16, 18, 36, 38	267236	6
244713	8	267063	8	267238	12
244714	8	267139	16, 18	267239	2
244726	6	267140	16, 18	267242	48
244730	10	267152	6	267245	8
244734	42	267160	2	267246	32
244735	42	267161	2	267247	2
244736	42	267162	2	267248	16, 18, 36, 38
244737	42	267166	16, 18, 36, 38	267251	12
244738	42	267167	16, 36	267254	4
244739	42	267171	18, 38	267255	4
244740	42	256172	16, 36	267256	4
244741	42	267180	8	267257	4
244742	42	267181	10	267258	4
244743	42	267182	10	267259	4
244744	42	267188	8	267260	22
244746	42	267189	8	267261	4
244747	2	267190	8	267262	4
244748	42	267192	8	267263	4
244750	20, 50	267193	18, 38	267264	4
244751	6	267194	16, 36	267265	14
244757	6	267195	8	267267	2
248406	10, 26	267196	8	267269	2
248502	26	267197	16, 18	267272	6
255168	24	267198	16, 18, 36, 38	267273	10, 26
259428	50			267274	10, 26
				267275	10

NUMERICAL LIST OF PARTS

Part No.	Page No.	Part No.	Page No.	Part No.	Page No.
267277	16, 18, 36, 38	267360	20, 40	267424	22
267286	4	267361	16, 18, 36, 38	267466	2
267287	4	267362	4	268063	10
267288	14	267365	16, 18, 36, 38	268064	8
267289	12	267366	16, 18, 36, 38	268065	8
267291	18	267367	16, 18, 36, 38	268066	8
267292	16	267368	14	268067	8
267293	4, 22	267369	14	270026	8
267300	2	267370	16, 18, 36, 38	270149	26
267304	26	267371	16, 18, 36, 38	270653	10
267307	30	267374	46	270830	24
267308	26	267395	6	270880	16, 18, 36, 38
267309	30	267396	6	271017	6
267310	30	267397	6	272142	2, 22, 26
267311	30	267398	6	276046	24
267312	30	267399	6	276061	16, 18, 36, 38
267313	30	267400	6	276160	24
267314	28	267403	22	276165	24
267315	28, 34	267404	22	276171	24
267316	14	267405	24	276173	24
267317	30	267406	24	276174	24
267318	26	267407	24	350231	46
267321	4	267408	22	350366	10
267322	4	267409	22	350393	10, 26
267323	42	267410	22	350405	40
267325	42	267411	22	350440	8
267326	42	267412	22	350464	12
267327	36, 38, 40	267413	22	350467	8
267328	38	267414	24	350477	8
267329	36	267415	24	350492	2
267330	32	267416	24	350507	24
267331	32	267417	24	350548	8
267335	44	267418	24	350563	6
267336	34	267419	24	350564	16, 18, 36, 38
267341	26	267421	22	350566	4
267351	16, 18, 36, 38	267422	22	350574	20, 40
267355	20, 40	267423	22	350581	12
267356	20, 40			350588	28, 34
267357	16, 18, 20			350595	16, 18, 36, 38
267358	20, 40				
267359	20, 40				

NUMERICAL LIST OF PARTS

Part No.	Page No.	Part No.	Page No.	Part No.	Page No.
350708	46				
508279	16, 36				
508280	18, 38				
508282	4, 22				
508283	6				
508310	26				
508314	22				
508315	2				
508341	24				
508342	24				
508354	24				